

Refurbishment site guidance for solid-walled houses – ground floors

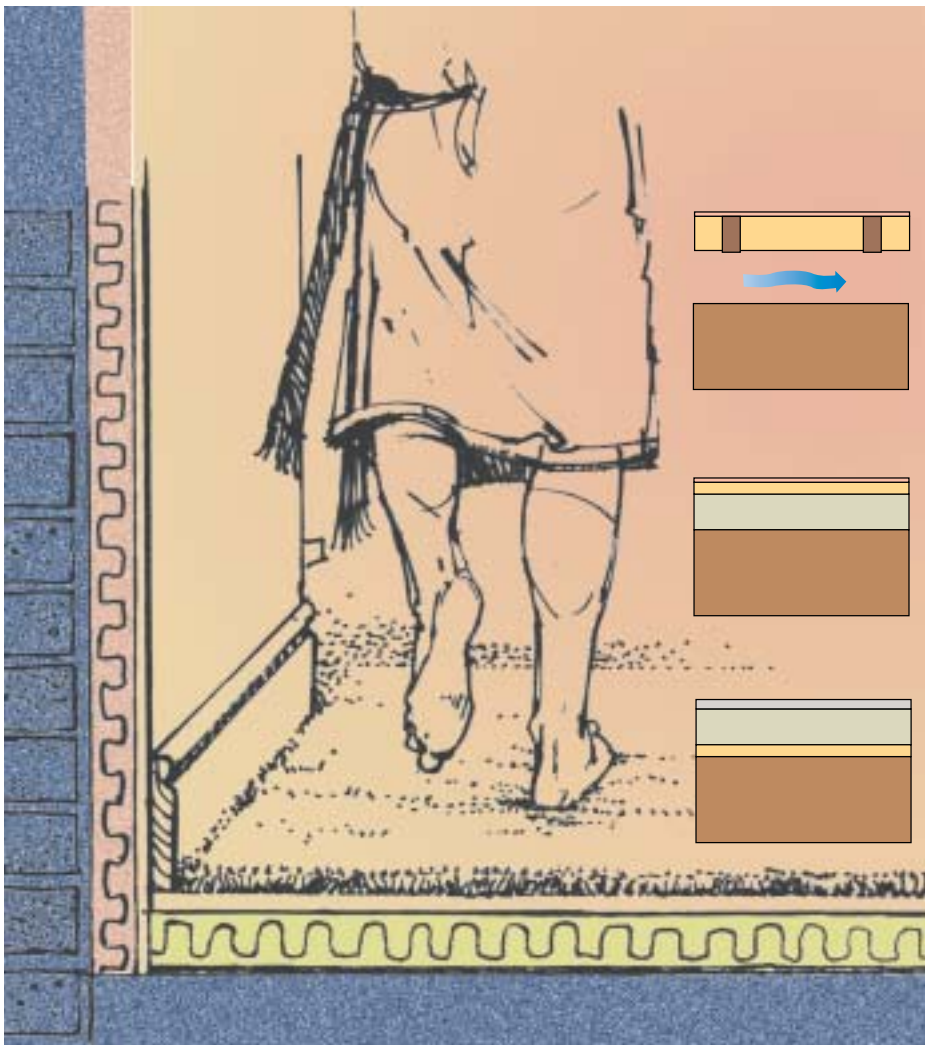

- What energy savings to aim for
- Key points to consider
- Energy savings and SAP ratings
- Environmental considerations



HOUSING
ENERGY EFFICIENCY

BEST PRACTICE
PROGRAMME

INTRODUCTION

THE STATIONERY OFFICE

The Stationery Office, London
Tel: 0870 600 5522, web:
www.tso.co.uk

Regulations (National Details)

These documents can be obtained from The Stationery Office, London

www.tso.co.uk/bookshop.

- The Building Regulations 2000 (England and Wales) Part L1 are set out in *The Building Regulations 2000, Approved Document L1 Conservation of Fuel and Power*
- The relevant Building Standards for Scotland are set out in *The Building Standards (Scotland) Regulations 1990, 6th amendment, Technical standards to Part J, Conservation of Fuel and Power*
- The relevant Building Standards for Northern Ireland are set out in *Building Regulations (Northern Ireland) Part F Conservation of Fuel and Power*

This is one in a series of Guides aimed at architects, builders, local authorities and housing associations. It provides advice on which insulation methods are most appropriate for floors and the thickness of insulation needed to achieve a good level of energy efficiency.

Other relevant Guides are:

GPG 295 Refurbishment site guidance for solid-walled houses – windows and doors

GPG 296 Refurbishment site guidance for solid-walled houses – roofs

GPG 297 Refurbishment site guidance for solid-walled houses – walls

GPG 155 Energy efficient refurbishment of existing housing

REGULATIONS

Building regulations vary between the nations. Building control at the local authority should be consulted for individual national standards (see left). Where applicable all aspects of national building regulations should be met.

TERMS USED IN THIS GUIDE

R-value (thermal resistance - m²K/W).

The R-value represents the resistance that a series of elements will provide to the passage of heat energy. It is affected by the conductivity of the element and its thickness. The higher the R-value the greater the resistance (the better the insulation effect). Because thermal properties of individual products vary, conductivity value (λ) should be checked with the manufacturer.

Vapour control layer. An impervious membrane, usually a polythene sheet or aluminium foil facing. It is placed on the warm side of insulation to prevent water vapour generated in the house from entering and condensing on the cold parts of the construction.

The Guide lists the technical points to be aware of, and the most suitable insulation materials.

SAP RATINGS

The Standard Assessment Procedure (SAP) is an energy rating which estimates the space and water heating costs (based on the size of the property and its heating and hot water system) and converts them into a rating on a scale from 1 to 120. The higher the number, the lower the energy consumption. The SAP rating can be used to compare the relative benefits of different energy efficiency measures.

'The Government's Standard Assessment Procedure for the energy rating of dwellings. 2001 edition' (available from www.bre.co.uk/sap2001 or telephone 01923 664258).

| SAP rating | | Typical annual heating and hot water costs |
|------------|---|--|
| 43 | typical mid-terrace house basic gas central heating | £500 |
| 44 | ground floor insulation added | £490 |
| 85 | fully insulated and double glazed | £210 |
| 100 | fully insulated, double glazed and with gas condensing boiler | £160 |

TIMBER FLOOR – ACCESS FROM ABOVE

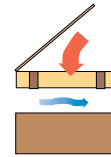

Unless the house has a cellar or basement, adding insulation to a timber ground floor is only really feasible if the floorboards are taken up to allow access to the space between the joists.

WHAT TO AIM FOR

For best practice aim for an insulation R-value of 3.75 m²K/W. The heat loss through a ground floor is greatest at the edges of the floor. This explains why the U-values for end-terrace houses are greater than for mid-terrace houses.

KEY POINTS

- The cross ventilation of the space below the timber floor must be maintained to remove moisture and prevent timber rot and mould growth. Do not block ventilation openings with insulation.
- Do not place a vapour control layer in a timber ground floor – it may trap moisture.
- Just as important as insulating the floor is to seal any gaps in the ground floor. This prevents cold draughts entering the house from the ventilated space under the floor.
- Adding central heating for the first time will cause wood to gradually dry out and shrink over the first one or two heating seasons. This will inevitably result in gaps and cracks for cold air to enter from the ventilated space under the floor, especially in older houses with square-edged floorboards.

Insulation values using mineral wool insulation or expanded polystyrene (average $\lambda = 0.038$ W/mK)

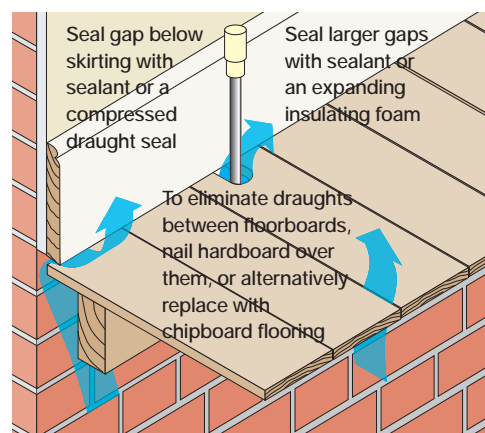
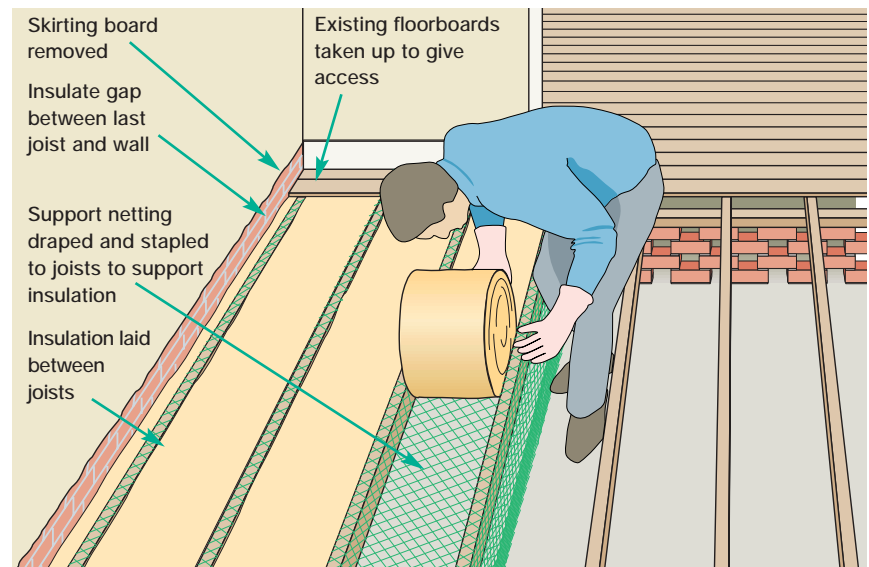
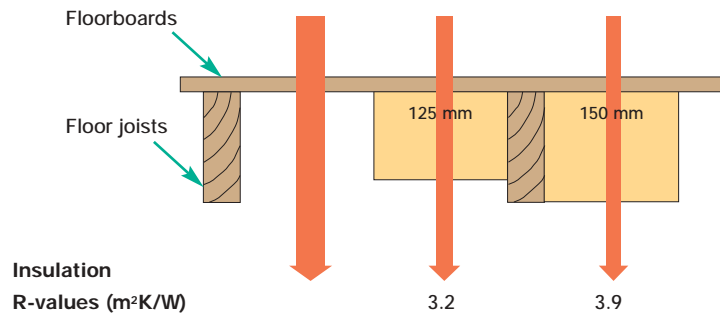
**MATERIALS**

- Rolls of mineral wool quilt 100 – 150 mm thick are readily available as loft insulation. Thinner quilts will need to be ordered.

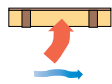

TIMBER FLOOR – ACCESS FROM BELOW

Insulation values using extruded polystyrene insulation (average $\lambda = 0.030 \text{ W/mK}$)

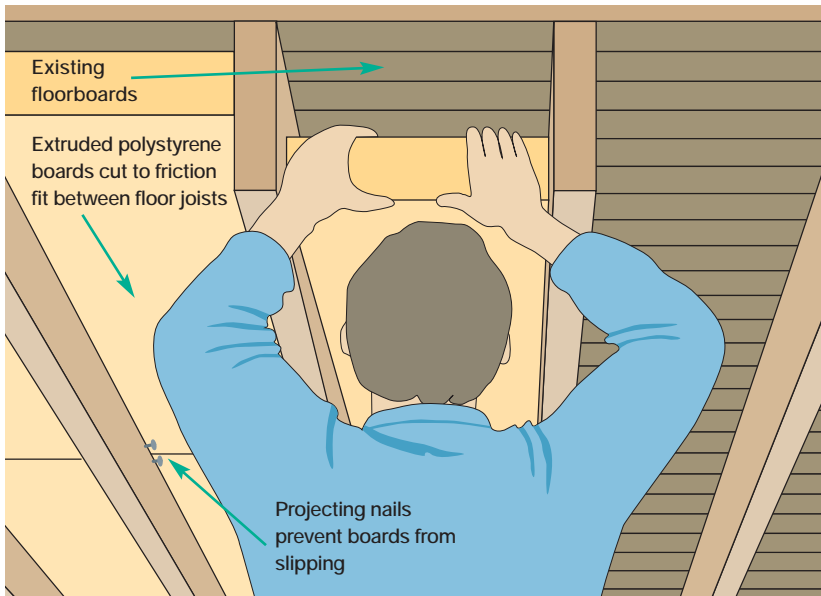
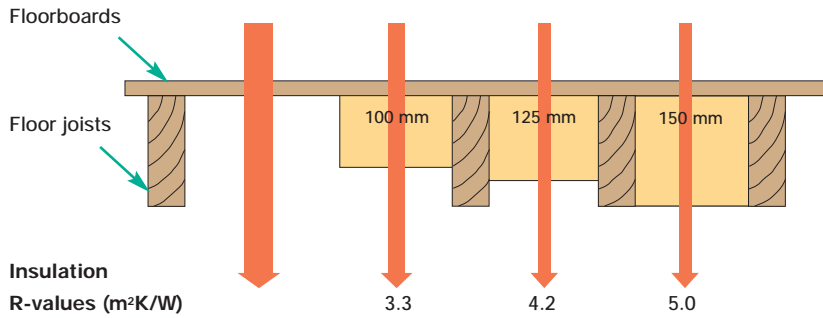

Note. Any fire protection material removed from the underside of the joists to install insulation should be re-instated.

MATERIALS

- Select a self-extinguishing grade of polystyrene, or alternatively nail plasterboard to the underside of the joists.

Cellars and basements allow insulation to be readily installed in a timber ground floor.

WHAT TO AIM FOR

For best practice aim for an insulation R-value of $3.75 \text{ m}^2\text{K/W}$. The R-values for mineral wool insulation between the joists are shown on the previous page. The illustration on the left shows the R-values for extruded polystyrene insulation.

KEY POINTS

- Insulation must fully fill the space between the joists. Mineral wool quilt can be supported on netting, expanded and extruded polystyrene boards can be held in place by projecting nails, as shown.
- The space between joists is usually less than 400 mm, so standard 400 mm wide loft insulation quilt can usually be 'friction fitted' between the joists. Do not over compress the insulation, as it is the air between the fibres that provides the thermal insulation. Expanded and extruded polystyrene boards will need to be cut to fit.
- Place the insulation tight up to the underside of the floorboarding to prevent cold draughts getting behind the insulation.
- The cross ventilation of the space below the timber floor must be maintained to remove moisture and prevent timber rot and mould growth. Do not block ventilation openings with insulation.
- If the cellar or basement is used for general storage, it is recommended that you fix a plasterboard ceiling to provide fire resistance. If the basement contains items with a higher fire risk, such as a boiler, tumbler drier, etc, expert advice should be sought and a smoke alarm fitted.
- Ensure electrical cables do not come into contact with polystyrene – cable embrittlement can occur when plasticised PVC comes into contact with polystyrene.
- Do not place a vapour control layer in a timber ground floor – it may trap moisture.
- Just as important as insulating the floor is to seal any gaps in the ground floor. This prevents cold draughts entering the house from the ventilated space under the floor.

EXISTING CONCRETE GROUND FLOOR



The only simple way of insulating an existing concrete ground floor is to add insulation and a new floor deck on top of the existing floor.

WHAT TO AIM FOR

For best practice aim for an insulation R-value of 2.5 m²K/W. The heat loss through a ground floor is greatest at the edges of the floor. This explains why the U-values for end-terrace houses are greater than for mid-terrace houses.

KEY POINTS

- The raised floor level will usually require the skirting boards to be removed and re-fixed and doors to be reduced in height and can cause problems with unequal or excessive step heights at staircases and external doors. These aspects may be unacceptable in terms of other building regulation requirements and could rule out insulating the floor.
- Ensure electrical cables do not come into contact with polystyrene – adverse reactions can occur when plasticised PVC comes into contact with polystyrene.
- The tongue and groove joints in the chipboard should be glued using a waterproof glue.
- Leave a 10 mm gap between the chipboard and the room perimeter. This allows the chipboard to expand due to moisture and temperature changes (the gap is covered by the skirting board).
- Use moisture-resistant flooring grade chipboard with tongued and grooved edges on all four sides (BS 7916, see back page for details).
- If the existing concrete floor suffers from dampness, lay a 1000 gauge polythene sheet as a vapour control layer between the insulation and chipboard. Alternatively, lay a damp-proof membrane over the existing floor.

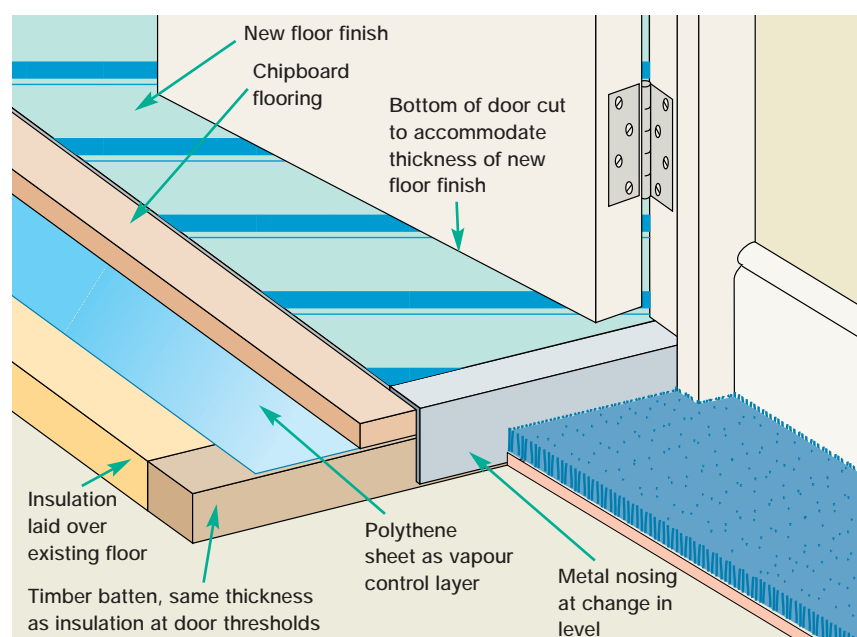
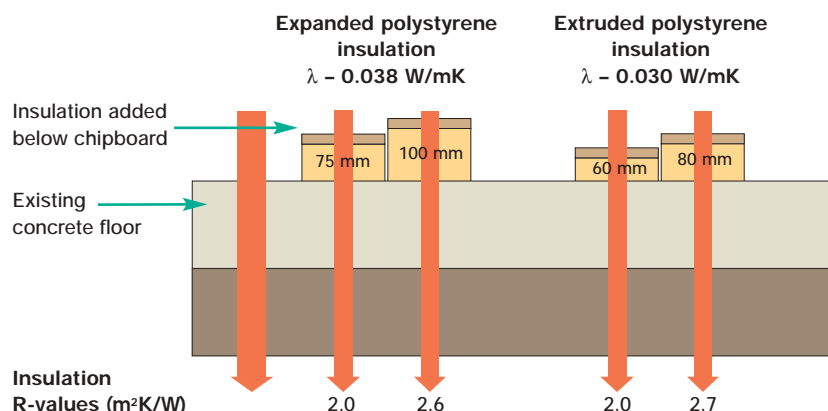
**MATERIALS**

- Expanded polystyrene is readily available at builders' merchants. Composite boards of insulation bonded to chipboard are less widely available and may need to be ordered.
- Extruded polystyrene is more expensive than expanded polystyrene, but is better at resisting moisture and is more compression resistant.

NEW CONCRETE GROUND FLOOR – INSULATION ABOVE SLAB

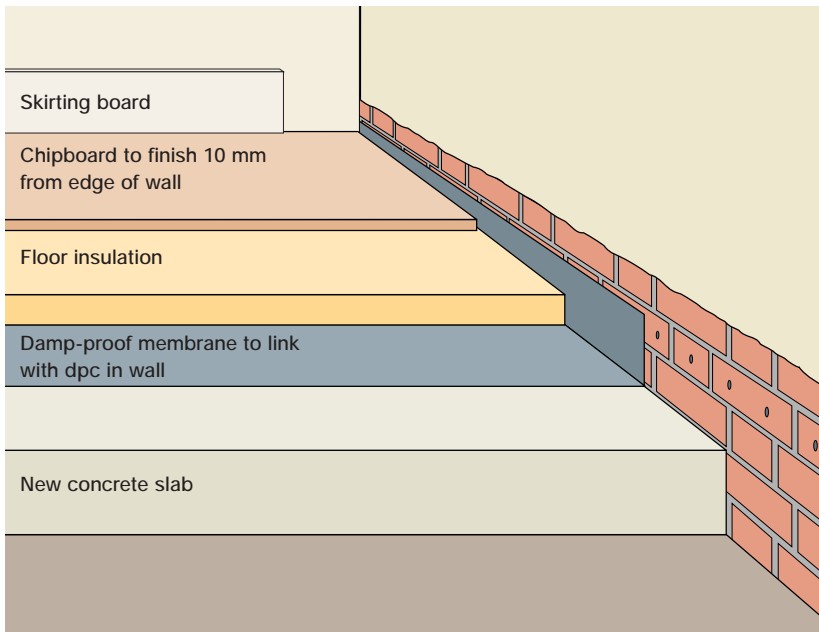
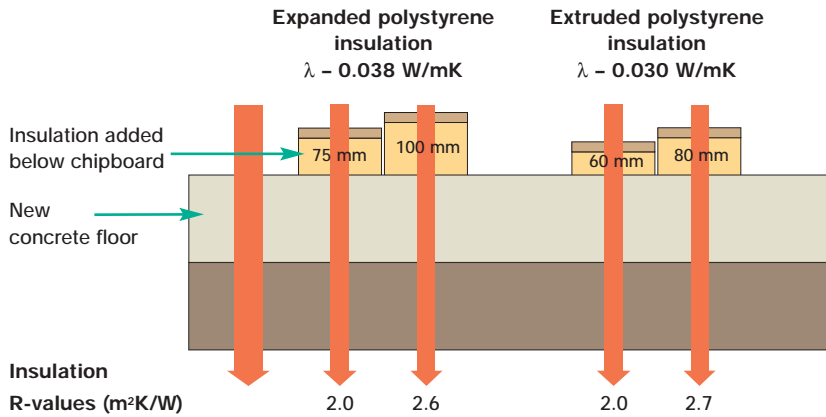
**MATERIALS**

- Expanded polystyrene is readily available at builders' merchants. Composite boards of insulation bonded to chipboard are less widely available and may need to be ordered.
- Extruded polystyrene is more expensive than expanded polystyrene, but is better at resisting moisture and is more compression resistant.

Placing insulation above the concrete slab helps the room to warm up quickly when the heating is switched on.

WHAT TO AIM FOR

For best practice aim for an insulation R-value of 2.5 m²K/W.

KEY POINTS

- Place the damp-proof membrane above the concrete slab, to prevent moisture from the drying out concrete slab from affecting the new floor finishes.
- With a chipboard floor deck and a damp-proof membrane above the slab, there is no need to wait for screeds or concrete floors to dry out. The insulation and chipboard can be walked on immediately after laying and are ready to receive any floor finish.
- The tongue and groove joints in the chipboard should be glued using a waterproof glue.
- Leave a 10 mm gap between the chipboard and the room perimeter. This allows the chipboard to expand due to moisture and temperature changes (the gap is covered by the skirting board).
- Ensure electrical cables do not come into contact with polystyrene – adverse reactions can occur when plasticised PVC comes into contact with polystyrene.
- Use moisture-resistant flooring grade chipboard with tongued and grooved edges on all four sides (BS7916).
- Ensure that finished floor level coincides with the previous level to avoid unequal or excessive step heights at external doors or staircases.

NEW CONCRETE GROUND FLOOR – INSULATION BELOW SLAB



This is the better option where the new floor is in a warm south-facing room. The concrete slab helps to absorb heat during warm sunny days and limit overheating.

WHAT TO AIM FOR

For best practice aim for an insulation R-value of 2.5 m²K/W. The heat loss through a ground floor is greatest at the edges of the floor. This explains why the U-values for end-terrace houses are greater than for mid-terrace houses.

KEY POINTS

- Place an upstand of insulation around the perimeter of the room, the same thickness as the concrete slab – this limits heat loss through the edge of the slab.
- The joints between the insulation boards should be taped with a water-resistant tape – this stops concrete seeping between the joints.
- Ensure that finished floor level coincides with the previous level to avoid unequal or excessive step heights at external doors or staircases.

Expanded polystyrene insulation $\lambda - 0.038 \text{ W/mK}$

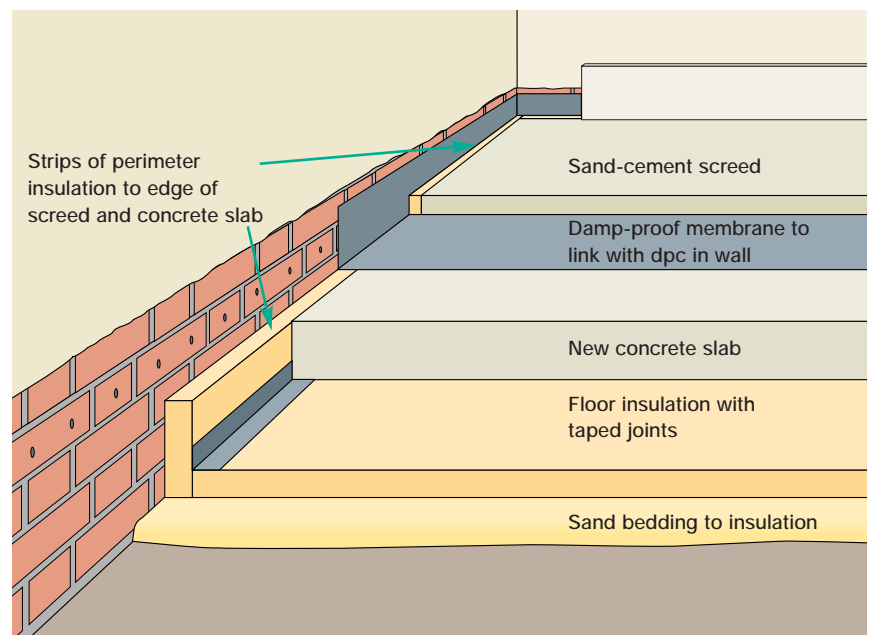
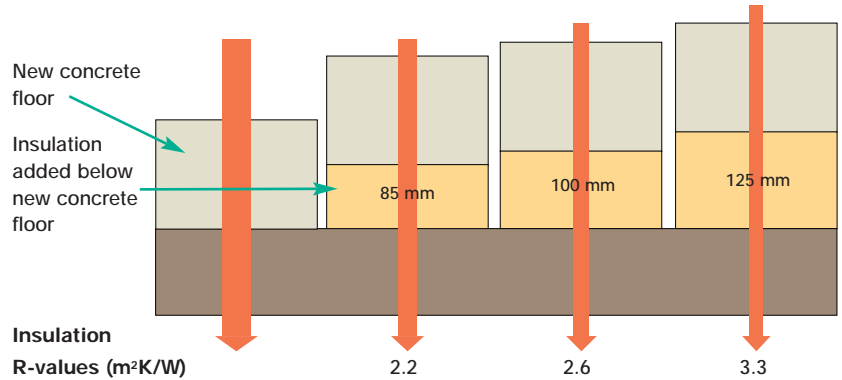
**MATERIALS**

- Expanded polystyrene is readily available at builders' merchants. Composite boards of insulation bonded to chipboard are less widely available and may need to be ordered.
- Extruded polystyrene is more expensive than expanded polystyrene, but is better at resisting moisture and is more compression resistant.

ENVIRONMENTAL CONSIDERATIONS AND FURTHER INFORMATION

ENVIRONMENTAL CONSIDERATIONS

There is growing global pressure to ensure that construction materials are sustainable. Whilst energy efficiency initiatives over the last 30 years have reduced the energy needed to heat a typical house considerably, initiatives to reduce the impact from construction materials have been comparatively slow.

The Green Guide to Housing Specification (Anderson and Howard, BRE, 2000) provides a useful reference for construction products, giving A,B,C environmental ratings for over 250 specifications. This definitive guide, developed over 20 years and supported in its current form by the National House-Building Council (NHBC), is predominantly based on life cycle assessment data from the DETR-supported BRE Environmental Profiles scheme. The Guide contains an extensive list of references to all of its sources of data.

The use of insulation in the building fabric will significantly reduce the operational environmental impact of the building over its lifetime. This benefit will outweigh the embodied environmental impact of the insulation materials. To minimise the embodied impact however, specifiers should avoid foam insulation materials that use blowing agents which cause ozone depletion or global warming, such as HCFCs or HFCs. Alternative blowing agents such as carbon dioxide or pentane are less environmentally damaging.

For best overall environmental performance, look to renewable or recycled materials such as cork, recycled cellulose, flax or sheep's wool, foams blown using pentane or CO₂ and low density mineral wool or glass wool, all of which have high ratings in the Green Guide to Housing Specification and have similar insulation properties to mineral wool and expanded polystyrene. Lower density glass and mineral wools should be used in preference to denser ones where possible, as their environmental impact increases proportionally with their weight.

HOUSING ENERGY EFFICIENCY BEST PRACTICE PROGRAMME DOCUMENTS

The following Housing Energy Efficiency Best Practice programme publications are available from the HEEBPp Helpline, telephone 01923 664258, or visit the website www.housingenergy.org.uk.

Good Practice Guide (GPG)

- GPG 155: Energy efficient refurbishment of existing housing
- GPG 295: Refurbishment site guidance for solid-walled houses – windows and doors
- GPG 296: Refurbishment site guidance for solid-walled houses – roofs
- GPG 297: Refurbishment site guidance for solid-walled houses – walls

FURTHER READING

BRE

Available from www.brebookshop.com
email brebookshop@emap.com
01923 664262

- BR 262: Thermal insulation: avoiding risks (2002 edition)
- BR 390: The Green Guide to Housing Specification

BRITISH STANDARDS INSTITUTION

389 Chiswick High Road, London W4 4AL.
Tel: 020 8996 9000, web: www.bsi.global.com

British Standards (BSI)

To order BSI standards telephone 020 8996 9001.
BS 7916: 1988. Code of practice for the selection and application of particleboard, oriented strand board (OSB), cement bonded particleboard and wood fibreboards for specific purposes.

Energy Efficiency Best Practice in Housing

Tel: 0845 120 7799
www.est.org.uk/bestpractice

Energy Efficiency Best Practice in Housing is managed by the Energy Saving Trust on behalf of the Government. The technical information was produced by BRE.

© Crown Copyright First Printed March 2000 And Revised November 2002

