



Energy Efficiency Best Practice in Housing

Domestic heating: solid fuel systems



Guidance for installers and specifiers



Energy
Saving
Trust

1. Introduction to Best Practice	3	7. Controls	15
1.1 Energy efficiency and Best Practice	3	7.1 Individual controls	15
1.2 Energy consumption and emissions	4	7.2 Selecting controls for Best Practice	17
		7.3 Further control improvements	18
2. UK building regulations	5	8. Best Practice	19
2.1 England and Wales	5		
2.1.1 New buildings	5		
2.1.2 Existing buildings	6	9. Energy Efficiency	21
2.2 Scotland	7	9.1 The Standard Assessment Procedure (SAP)	21
2.3 Northern Ireland	8	9.2 Energy consumption and running costs	22
		9.3 Carbon dioxide emissions	22
3. Solid fuel and energy use	9	10. System selection - practical issues	23
3.1 Fuel types	9		
3.2 Smoke control	9		
4. Chimneys, hearths and air supplies	10	11. Installing central heating systems	26
		11.1 'Competent person' requirements	26
5. Space and water heating	11	11.2 Chimneys	26
5.1 Open fires	11	11.3 Installing controls	26
5.2 Roomheaters and stoves	11	11.4 Water treatment	27
5.3 Independent boilers	12	11.5 Fuel storage	27
5.4 Cookers	12	12. Commissioning and handover	28
6. Central heating and hot water systems	13	12.1 Commissioning	28
6.1 Open and sealed systems	13	12.2 Advice to the householders	28
6.2 Domestic hot water	13	12.3 Servicing	28
6.3 Upgrading systems	13	Appendix A - Definitions of heating controls	29
6.4 Dual-fuel ('link-up') heating systems	13		
6.5 Heat emitters	14	References	30
6.6 Circulator pumps	14		

Home energy use is responsible for 28 per cent of UK carbon emissions which contribute to climate change. By following Best Practice standards, new build and refurbished housing will be more energy efficient and will reduce these emissions, saving energy, money and the environment.

This guide is designed to help installers, specifiers and purchasers of solid fuel appliances to choose the most appropriate system for their needs. It covers solid fuel appliances which contain a boiler providing hot water for the space heating and domestic hot water needs of the household. It also covers room heaters.

Specifically, it offers guidance on the selection of appliances, hot water storage vessels and controls for those wishing to improve energy efficiency, reduce running costs and reduce carbon dioxide (CO₂) emissions. It describes the main types of solid fuel heating and hot water appliances available, the kinds of system to which they can be fitted - as well as the key points that should be considered when choosing appliances.

When making selections, reference should be made to the relevant building regulations and manufacturers' instructions should always be followed. Information is available on the design of central heating systems^(1,5,12). This document does not deal with the detailed requirements for chimneys or hearths.

This guide only covers the use of mineral based fuels such as coal, anthracite, coke, briquettes etc and wood in the form of logs and briquettes. These fuels are burned in appliances, approved by HETAS, such as boilers, cookers and room heaters and also multi-fuel appliances burning both wood and solid mineral fuels. It does not cover appliances specifically designed to burn wood pellets or wood chips - a separate guide is planned for this.

The CO₂ emitted as a result of burning wood is closely balanced by the carbon extracted from the atmosphere in recent times by equivalent tree growth (there is a small amount due to the industrial activities of tree-felling, cutting, processing and transportation). The 'net' carbon emissions are therefore small, and this gives an environmental benefit compared to mineral fuel.

The Solid Fuel Association (www.solidfuel.co.uk), representing the coal and smokeless fuel industry as well as a number of appliance manufacturers, provides advice and guidance to consumers, specifiers and the heating trade.

HETAS has been in existence for more than 60 years and is 'the independent UK body recognised by DEFRA (Department for Environment Food and Rural Affairs) for the official testing and approval of domestic solid fuels, solid fuel burning appliances and associated equipment and services'. HETAS also covers all solid fuels including wood logs, wood pellets and wood chips and the appliances to burn them. It publishes an annual guide to approved solid fuel products and services and maintains a register of competent heating engineers at www.hetas.co.uk.

1.1 Energy efficiency and Best Practice

The overall energy efficiency of a heating appliance or system determines to a large extent both the running costs and the associated CO₂ emissions. To achieve Best Practice, appliances with the maximum efficiency should be chosen.

Over the years, efficiency has generally increased. However, for an equivalent amount of heat, burning mineral solid fuel produces greater quantities of CO₂ than natural gas, LPG or heating oil. While emissions are theoretically less than for electricity, the lower efficiency of solid fuel appliances will often mean in practice they are higher.

The efficiency of an appliance varies according to type and design and will be influenced by:

- whether it is a closed or open appliance;
- combustion control (i.e. fan, damper, etc);
- turn-down range;
- chimney design;
- ventilation;
- fuel type and quality;
- ignition method.

For a central heating system, key factors include:

- system design - whether fully pumped or semi-gravity (pumped space heating but gravity-fed domestic hot water);
- system controls;
- the design of the chimney and its position in the dwelling;
- load on the boiler due to the weather;
- sizing of boilers and radiators;
- installation and commissioning;
- ratio of space/water heating;
- system balancing;
- servicing and maintenance intervals.

When older appliances are replaced, newer and more advanced technology can result in substantial improvements in energy efficiency.

How to use this guide

The guide is set out as follows:

Section 2 explains the building regulations for heating and hot water systems in different parts of the UK.

Sections 3-7 describe the fuels, appliances, systems and controls currently available.

Section 8 provides a ready-made central heating system specification.

Section 9 focuses on the benefits of Best Practice and considerations of energy efficiency.

Section 10 contains comprehensive tables on the practical questions that need to be addressed when selecting appliances and systems.

Section 11 addresses issues concerning installation.

Section 12 gives advice on commissioning, servicing and the information needed by the customer.

The Appendix provides definitions of controls.

Note: the superscript numbers in brackets in the text refer to documents listed at the end of this guide.

1.2 Energy consumption and emissions

Appliances for heating and hot water produce the greatest proportion of domestic (CO₂) emissions. They consume far more energy than household appliances.

The average household with solid fuel central heating consumes about 23,000 kilowatt-hours (kWh) of energy each year. Of this, 84 per cent is for heating and hot water. To reduce fuel costs and cut emissions, it is particularly important to choose efficient boilers and install them in suitably designed and controlled systems.

Figure 1: Energy use and emissions in homes heated by solid fuel (anthracite).

Energy consumption

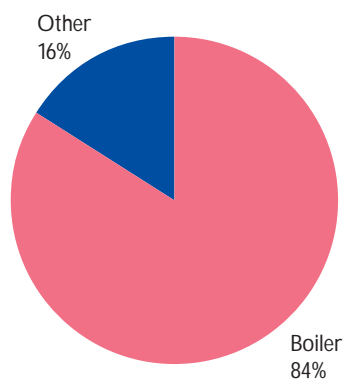

CO₂ emissions

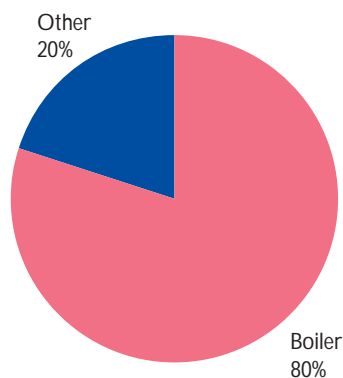

Relative costs

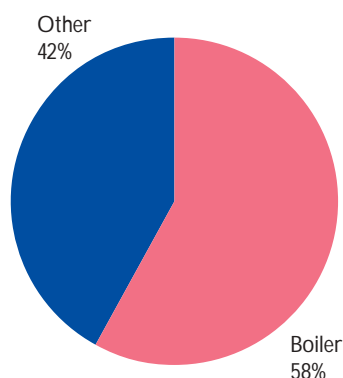



This section outlines the minimum standards for heating efficiency as set out in the building regulations. The remainder of this guide then concentrates on Best Practice - a higher standard.

There are different building regulations in England and Wales, Scotland, and Northern Ireland. All contain provisions for conservation of fuel and power^(2,3,4). These restrict the type of heating system that may be installed in new dwellings. In the case of England and Wales, new and replacement heating systems in existing dwellings are also covered. A summary of the main points of the regulations is given below.

Other parts of the regulations (Part J in England and Wales, Section 6: Energy, of the Domestic Technical Handbook in Scotland and Part L in Northern Ireland^(8,28,29)) deal with the related issues of the safety of heating installations and with fuel storage.

2.1 England and Wales

The building regulations set a legal requirement to make 'reasonable provision for the conservation of fuel and power in dwellings'. However, the approved guidance notes that 'there may well be alternative ways of achieving compliance' (Part L1) and different strategies can be adopted provided it can be shown they are at least as good as those given in the guidance.

2.1.1 New buildings

New dwellings must comply with Part L1 of the Regulations⁽²⁾. Three methods of demonstrating compliance are given and these take boiler efficiencies into account. Only two may be used in the case of solid fuel - the target U-value and the carbon index methods. In each case, the solid fuel appliance used should have an efficiency at least as high as that recommended for its type in the HETAS certification scheme⁽²¹⁾.

The 'target U-value' method

Under this method, an average U-value (see panel) is calculated from the values for the various elements of the building envelope and it must not exceed a target value for the structure. Where solid fuel appliances are employed, the nominal target value must be divided by an adjustment factor of 1.15 to arrive at the final figure. This is to compensate for higher carbon emissions compared with gas and oil-fired boilers.

The carbon index method

With the carbon index method (see panel), a value of 8.0 or better must be achieved. The choice of fuel will have a direct impact on the carbon index.

U-values measure the rate of heat transfer through materials, in units of watts per square metre per degree of temperature difference (W/m^2K). The lower the figure, the lower the rate of heat loss.

The Standard Assessment Procedure (SAP) is the UK Government's procedure for calculating home energy ratings which enable the householder to compare the energy performance of different buildings⁽¹⁵⁾.

The carbon index is calculated as part of the SAP. CO_2 is emitted as a result of burning fuel, or generating electricity, to meet the demand for space and water heating. Expressed on a scale from 0.1-10.0, higher values represent lower emissions.

Storage vessels

Hot water storage vessels should be insulated in accordance with BS1566 or BS3198^(6,7), and the internal heat exchanger should be sized accordingly.

Controls

Zone controls should allow different air temperatures to be set for living and sleeping areas (other than in small open-plan flats and other properties where these areas are not separated). In most dwellings, both temperature zones can be controlled by a single time switch or programmer channel. However, in properties with a floor area of more than $150m^2$, multiple timing zones are required (with no zone larger than $150m^2$).

Pipework

Pipes should be insulated wherever they pass outside the heated living space. In addition, all hot water pipes connected to the hot water cylinder (including the vent pipe and the primary flow and return) should be insulated for at least 1m from the connection.

Commissioning

Upon completion of the installation, the systems should be inspected and then brought into service so that it operates efficiently and meets its specified performance levels. A commissioning certificate should be made available to the client and the building control body. The owner or occupier should also be given information on the operation and maintenance of the system.

2.1.2 Existing buildings

Part L1 of the Building Regulations applies to work on 'controlled services or fittings' in existing dwellings, as well as in new ones. Certain types of heating system are 'controlled', including central heating systems with boilers. In particular, any new boiler (whether or not it replaces an existing unit) should meet or exceed an efficiency recommended for its type in the HETAS certification scheme⁽²¹⁾.

New or replacement hot water storage vessels and controls should meet the same requirements as in new buildings. Ensuring adequate controls are in place should be a priority whenever a boiler or hot water storage vessel is installed. Commissioning and handover procedures should also be undertaken as in new buildings.



2.2 Scotland

From 1 May 2005, new dwellings must comply with the Building (Scotland) Regulations⁽³⁾. The methods of demonstrating compliance for new buildings are similar in principle to those in England and Wales described above, though there are differences in the calculations. There are three alternative methods of demonstrating compliance in which the efficiency of the boiler is taken into account.

The elemental method

More demanding U-values are involved here when solid fuel appliances are the main source of heating.

The 'target U-value' method

In the target U-value method, an average U-value is calculated for the various elements of the building envelope and must not exceed a target which depends on the ratios of total floor, ground floor, and roof areas to the total area of all exposed elements of the dwelling. Where solid fuel appliances are employed, the nominal target value must be divided by an adjustment factor of 1.15 to arrive at the final figure. This is to compensate for higher carbon emissions compared with gas and oil-fired boilers.

The carbon index method

In the carbon index method (see panel - page 5), a result of 8.0 or higher must be obtained when the overall energy performance of the building is assessed under SAP. The fuel used for heating and hot water directly affects the carbon index.

Storage vessels, pipework and controls

Hot water storage vessels must be adequately insulated, and all pipes used for space heating and hot water supply must be suitably insulated where they lie outside the heated living space.

The space heating system must be controlled by room thermostats or thermostatic radiator valves (TRVs), and an adjustable seven day time switch or programmer. A solid fuel boiler must have an automatic control (thermostat) that reduces firing to the minimum burning rate.

Commissioning

At completion of installation, systems must be inspected, tested, and brought into service so as to meet the specified performance and operate efficiently. Written information on the operation and maintenance of the system must be provided for the occupier.

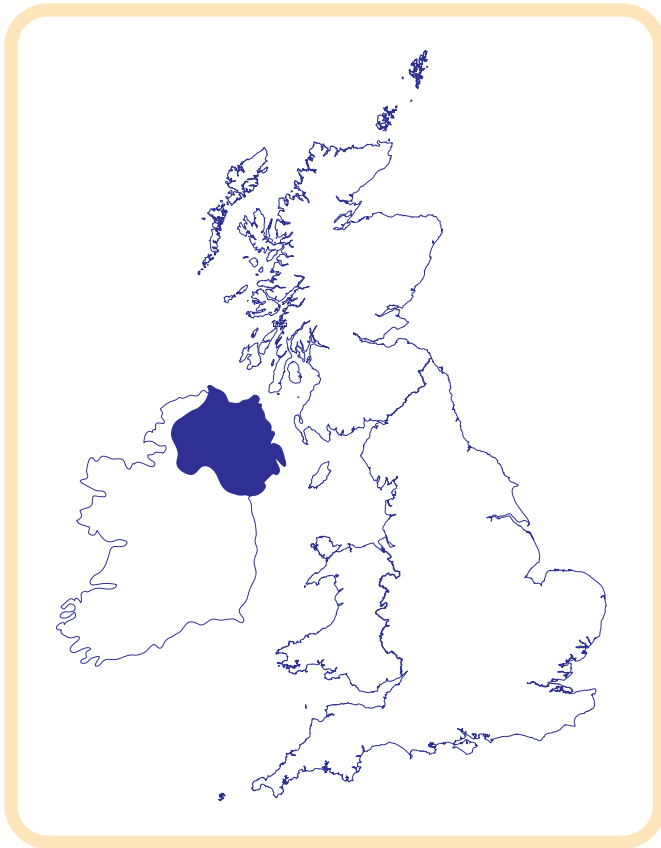

2.3 Northern Ireland

The relevant building regulations are the Building Regulations (Northern Ireland) 2000, and specifically Regulations F3 and F4. These call for 'reasonable provisions' to be made for space heating and hot water supply. Technical Booklet F: Conservation of fuel and power (December 1998)⁽⁴⁾ gives provisions that are deemed-to-satisfy the requirements of Regulations F3 and F4. Although it is not essential to follow Technical Booklet F, it is obligatory to comply with Regulations F3 and F4.

Technical Booklet F has two methods of demonstrating compliance, explained here. For both methods a SAP rating (see 9.1) must first be calculated, and different requirements then apply according to whether or not the SAP rating exceeds 60.

The elemental method

Under the elemental method, boiler efficiency is not specified explicitly, although it affects the SAP rating achieved. If the SAP rating is 60 or less then lower (more onerous) maximum U-values (see panel) are applied to the elements of the building fabric, which will tend to increase construction costs.

The 'target U-value' method

Under the target U-value method, the target is calculated by reference to the total floor area and total area of exposed elements, and raised (i.e. relaxed) where the SAP rating exceeds 60. The target can be relaxed further by as much as 10 per cent where there is a high efficiency heating system.

A heating system with a gas boiler of seasonal efficiency above 72 per cent qualifies, and between 72 per cent and 85 per cent the target U-value may be increased by up to 10 per cent pro rata.

Storage vessels, pipework and controls

Hot water storage vessels shall be insulated to a specified standard, and all hot water pipes connected to the vessel (including the vent pipe and primary flow and return) shall be insulated for at least 1m from the connection. Other pipes shall be insulated where they lie outside the heated living space.

The heating and hot water systems shall be controlled by thermostats or TRVs, allowing for independent zones where different temperatures are required (e.g. separate sleeping and living areas).

A time switch or programmer shall be provided to control operating periods.

3.1 Fuel types

The choice of fuel will depend on several factors including:

- type of appliance;
- fuel availability;
- manufacturers' recommendations;
- location of the dwelling (whether in a smoke control area or not).

So-called 'multifuel' appliances can burn both mineral fuel and logs. Burning time of different fuels, as well as ease of ignition, will depend on the proportion of volatile matter. In the UK, mineral fuels fall into the following categories.

- Natural smokeless fuels (anthracites). These are very low in volatiles and burn for long periods. They can be used in a wide variety of appliances, but are not recommended for open fires unless these are fan-assisted. Care is needed in selecting the correct size of fuel.
- Manufactured smokeless fuels (coke and briquettes). These also have low volatility and are suitable for a wide range of applications. If for use in smoke control areas, they must satisfy the requirements of the Clean Air Act⁽¹⁾.
- Bituminous coal. This is mainly used in open fires and should not be used in smoke control areas except in an exempted appliance. Coal properties vary.

The sale of coal, smokeless fuel and wood is regulated by both the Weights and Measures Act⁽⁹⁾ and the Trades Descriptions Act⁽¹⁰⁾.

3.2 Smoke control

A large proportion of dwellings in UK urban areas are in smoke control zones. Combustion systems have to comply with the Clean Air Act and appliances have to use authorised smokeless fuel unless they are specifically designed as smoke-reducing exempt appliances.

Bituminous coal emits higher levels of air pollution when burned and so can only be used in exempt appliances within smoke control areas. 'Smokeless fuels' such as anthracite, coke and briquettes that meet low emissions standards may be designated by DEFRA (Department for Environment Food and Rural Affairs) as 'approved fuels' for use in these areas.

For the safe and efficient use of any solid fuel appliance, it is essential to have a well-constructed chimney. This allows combustion products to be discharged safely to the outside atmosphere. Chimneys are generally divided into three types:

- existing masonry;
- custom-built;
- factory-made.

Existing masonry chimneys

These may be lined or unlined. Since 1985, all new masonry chimneys intended to be used with solid fuel have been lined with a suitable material such as clay. Before that date, proprietary liners were seldom used. Steady deterioration of the fabric over a period of time means that many chimneys require secondary lining and there are a number of proprietary techniques that have been developed for this purpose.

Custom-built and factory-made chimneys

New chimneys can be constructed of traditional materials or pre-fabricated using factory-made stainless steel or block systems.

Chimney design

All chimney and hearth construction, and the provision of correctly sized ventilation openings, must satisfy building regulations requirements (Part J in England & Wales, Section 3: Energy, of the Domestic Technical Handbook in Scotland and Part L in Northern Ireland). These apply for all solid fuels and it is essential that a pre-installation check of the chimney is carried out before any appliance is installed.

Key requirements in chimney design are as follows.

- It must have sufficient height - the temperature difference between flue gas and outside air provides the necessary updraft or 'pull' to expel the fumes.
- There should be no sharp bends or obstructions which offer resistance to the flow.
- Air leakage must be minimised to prevent unnecessary cooling of the flue gases.
- Careful planning of the chimney termination is needed to avoid high pressure zones.
- All chimneys must have provision for sweeping.

There must also be an adequate air supply to solid fuel appliances in order to ensure complete combustion of the fuel and the correct functioning of the chimney. Incomplete combustion leads to increased levels of smoke and carbon monoxide which is a serious health hazard.

Extractor fans must not be installed in the same room as an open-flue appliance or the room in which the permanent vent is located. There are some exceptions to this rule, e.g. in large rooms where there is sufficient replacement air to avoid spillage of combustion gases (although a spillage test must be carried out).

It is essential for safe and efficient operation that solid fuel chimneys are regularly inspected and cleaned.

Solid fuel appliances must be sited on a hearth constructed of suitably robust materials. Its dimensions should be such that, in normal use, the building fabric and furnishings are prevented from catching fire.

Further guidance on chimney design, installation and maintenance can be obtained from: the British Flue and Chimney Manufacturers Association (BFCMA)⁽²²⁾; the National Association of Chimney Engineers (NACE)⁽²³⁾; the National Association of Chimney Sweeps (NACS)⁽²⁴⁾; the Guild of Master Sweeps (GMS)⁽²⁵⁾; the Solid Fuel Association (SFA)⁽¹⁸⁾ and HETAS⁽¹³⁾.

All solid fuel appliances other than open fires are referred to as closed. Although they cannot be turned on and off electrically, they can be turned down when heat is not required. If the appliance includes a boiler, turn down is effected indirectly by stopping the pump and allowing the boiler thermostat to reduce the burn rate. Some appliances are fitted with a fan that enables combustion air to be reduced to a low level. This means the heat output can also be reduced to a minimum.

5.1 Open fires

Inset on a hearth, these give a visible fire and are not enclosed by doors or glass. Although they can burn many types of fuel, they do not have high thermal efficiency as the combustion air supply cannot be controlled. Heat is transferred to the room mainly by radiation, so the further from the fire the less heating effect. Open 'convector' fires (both inset and freestanding) are also available, with heat being transferred from a convection chamber to the room. These supply more heat than a comparable open fire and are somewhat more efficient. The 'dog grate' (sited in a recess or inglenook) has become popular over recent years, but is the least efficient of the open fire configurations because of its large open construction.

Figure 2: An open fire



Back boiler units (BBUs) can be fitted to an open fire. These will provide primary hot water which will then serve a domestic hot water cylinder as well as a radiator heating system. High output open fires with BBU now on the market will meet the space and water heating requirements of a traditional three-bedroom house. These are more efficient as they incorporate throat restrictors to limit the warm air that is drawn from the room.

Open fires do not have automatic air control to regulate the combustion rate. Many achieve partial control of air supply by adjusting the air inlet on the ash pit door and, where fitted, a flue damper. Note that it is a mandatory requirement that there is a correctly sized air vent so that the fire has

sufficient air for combustion and fume evacuation under all conditions.

While traditional and attractive in appearance, open fires have the disadvantages of slow response, poor turn down and lack of thermostatic control. These drawbacks lead to overheating and excessive fuel consumption. It is possible to fit some open fires with a 'firefront', normally a set of glass doors fitted to the front of the fireplace. This converts the open fire to a closed unit and will significantly improve its operating efficiency. The unit may also include thermostatic control.

Open fires	
Output range (kW)	Typical turn down
4-10	2.5-3.0 : 1

5.2 Roomheaters and stoves

These consist of a firebox and flue outlet enclosed behind a door of heatproof glass. By enclosing the fire, combustion air supply can be effectively controlled. This reduces the excess air entering the chimney and allows for greater control over the rate of burning. This increases operating efficiency substantially above that of the simple open fire.

This increased efficiency combined with a traditional and attractive appearance makes them the most popular type of solid fuel heating appliance.

Freestanding units coupled to a chimney with a pipe are referred to as stoves - which should not be confused with cooking appliances. As these are not built into the chimney breast, they have larger casings and, in some cases, an extra flue gas pass before discharge. Stoves therefore have cleaner combustion and higher efficiencies.

Figure 3: A stove



Backboilers

Variants with BBUs are also available. Providing an attractive focal point, these units are commonly used for solid fuel central heating systems. In such instances, it is important to ensure the right ratio between 'heat to room' and 'heat to water', which should be roughly proportional. The distribution of heat in the building (particularly within the room where the unit is located) needs to be carefully considered. If the appliance is oversized, heat output to the rest of the dwelling will be limited.

It is common to install a radiator in the same room as the appliance (it must have a TRV) so that adequate heating is available under most operating conditions. Sometimes, units have a damper fitted which controls the heat-to-water and heat-to-air ratio. When the damper is closed, the heat-to-room is at its maximum. When the damper is fully open, the greatest heat-to-water is achieved.

Many stoves and roomheaters are 'multifuel' appliances that can burn mineral fuel or wood. The more wood that is used, the lower the CO₂ emissions. This is because wood is a carbon-neutral fuel.

Roomheaters and stoves	
Output range (kW)	Typical turn down
6-12	4.0-5.0 : 1

5.3 Independent boilers



Figure 4: An independent boiler

These can provide full central heating for most dwellings and are available in a wide range of outputs and sizes. Batch fed units will provide domestic hot water and sufficient heat for a three to four bedroom house. Gravity-fed boilers (which have a large hopper over the fire box) will operate for up to 36 hours at minimum output and for 10 hours on full burn rate without refuelling or de-ashing. All of them burn small anthracite that feeds into the fire as necessary. Combustion is assisted by a built-in

thermostatically controlled fan, which helps adjust output to demand.

Gravity-fed units have a high turn down (around 10:1), which means that they can kindle at low combustion rates, compared with other solid fuel appliances. There is still some background heat given off when the boiler is turned down to minimum, helping to prevent condensation within the dwelling.

Independent boilers		
	Output range (kW)	Typical turn down
Batch fed	6-12	4.0-5.0 : 1
Gravity fed	13-24	10.0 : 1

5.4 Cookers

Solid fuel cookers come in a range of types, including: cooker only; cooker and domestic hot water supply; and those that provide partial or full central heating. They can burn a wide range of fuels and because of their high thermal inertia and sustained temperatures they have gained an enviable reputation for cooking quality.

Their design means that they inevitably produce constant background warmth and this may make them less suitable in modern housing which often only needs intermittent heating. Indeed, constant background warmth can sometimes make ambient temperatures uncomfortable during the summer. They are better suited to dwellings such as the traditional farmhouse where daily lifestyle centres around the kitchen.



Figure 5: Cooker with BBU

Cookers	
Output range (kW)	Typical turn down
4-23	4.0-5.0 : 1

6.1 Open and sealed systems

Solid fuel boilers and back boilers must be installed in an open-vented system meeting British Standards⁽¹⁾. Open-vented systems are so-called because they incorporate a separate vent pipe which is open to the atmosphere. Sealed systems (which use an expansion vessel) are not used since it is not possible to turn the heating off.

Open-vented systems also include a feed and expansion cistern to allow for changes in system water volume with temperature. The cistern must be at the highest point of the system which is usually in the loft, and protected from the risk of freezing.

All materials in normal contact with the water (e.g. the cistern, cover and components) must be capable of withstanding a temperature of 100°C. If fitted in a roofspace or exposed position, precautions against freezing need to be taken.

Figure 6 shows a typical pipework arrangement for a fully pumped system which is suitable for use with a solid fuel boiler. They can also be used in semi-gravity systems (see Section 7.2).

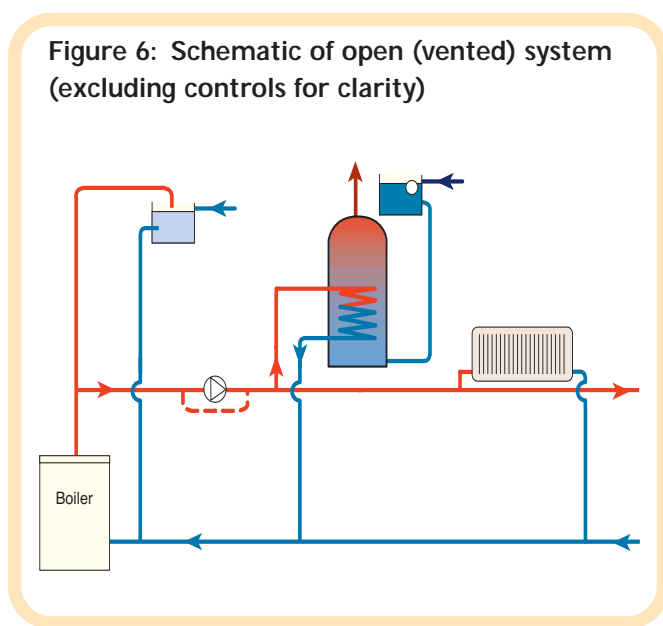

6.2 Domestic hot water

Systems should include a vented, indirect, double-feed storage cylinder for hot water. This should meet the relevant British Standards requirements⁽⁶⁾ and, where specified by the heating appliance manufacturer, should be suitable for gravity operation (even in a fully-pumped system, gravity circulation should be possible in the event of a control or power failure).

In dwellings with a single bathroom, a cylinder capacity of 120-140 litres is normally sufficient. Larger houses with more than one bathroom (and with separate showers) will need a higher capacity. Some manufacturers recommend the use of larger cylinders as this prevents heat wastage by providing a store for heat whilst the boiler is in 'slumber' mode.

Pre-coated cylinders should always be used in preference to those with separate jackets. Medium-duty cylinders do not meet building regulations requirements in England and Wales and should no longer be used in either new or replacement projects.

Thermal stores can be used to hold water at high temperature and these are heated by the boiler directly. They are available either for 'hot water only' or 'hot water and space heating' operation.

6.3 Upgrading systems

Many existing wet central heating systems are poorly controlled and of obsolete design. Poor design features which fail to meet Best Practice requirements include the following.

- Open appliances with poor control of air supply.
- Lack of cylinder thermostat and motorised valve, resulting in excessive temperatures for stored hot water.
- No room thermostat or TRVs, giving excessive room temperatures.
- Under-sized heat exchanger on the storage cylinder and inadequate insulation.

Important points to consider when replacing a solid fuel appliance include the following.

- Where the system is converted to fully pumped, or where a motorised valve is installed to improve hot water temperature control, system design must ensure that all the heat generated when the boiler is in slumber mode is dissipated. In addition, unsafe operation in the event of power or control failure must be prevented.
- Any slumber radiator incorporated in the system must not be fitted with user-operated valves or a TRV.
- The chimney must be correctly designed, sized and correctly constructed using suitable materials. It must also be provided with an appropriate terminal^(2,3,4,5).
- A purpose-made air vent must be included to ensure sufficient combustion air.

6.4 Dual-fuel ('link-up') heating systems

In some circumstances, it is possible to connect a solid fuel boiler (back boiler or stove) to an open-vented central heating system operating on another fuel, such as oil or gas. This 'link-up' offers the benefits of a dual-fired system. It has the appearance of a traditional solid fuel fire, together with possible advantages from reduced running costs and reduced emissions. However, these have to be carefully weighed against the extra capital costs involved.

Link-up can be achieved in a number of different ways, depending on the existing system (if there is one) and the size and output of appliances being linked. Particular care must be paid to safety, controllability and efficiency. It is essential to ensure that the solid fuel appliance has an unrestricted open vent and a separate cold water feed supply. Any motorised valves used must be of the 'normally open' type to prevent safety problems in the case of power or component failure.

Expert advice should be sought to ensure correct and safe pipework as well as electrical systems, and that the new system is energy efficient. Special products for link-up systems are available⁽¹⁸⁾.

6.5 Heat emitters

A wide range of heat emitters are available (see Table 1). Radiators remain the most popular type and modern versions are usually slightly smaller for an equivalent heat output. Many modern radiators also have a smaller water content, making for a faster warm-up.

The heat output of the radiators should be carefully calculated⁽¹²⁾. All of them, except slumber radiators and those in a room with a controlling room thermostat, should be fitted with a TRV.

Other important points include:

- radiators sited under windows counteract cold draughts and so give a more comfortable environment in the room;
- radiators should be installed close to the floor, preferably 100-150mm above finished floor level;
- wide, low radiators will be more effective at heating the room evenly than tall, narrow 'designer' styles;
- enclosures around radiators reduce the heat output.

6.6 Circulator pumps

A circulator pump must be selected with sufficient design pressure and flow rate for the total system resistance when operational. If the pump is undersized or is set too low, the flow may be unable to provide adequate heating. On the other hand, a pump that is larger than required will result in excessive water velocity noise as well as unnecessary electricity consumption.

Circulator pumps set at an unnecessarily high speed may reduce heating performance and will increase electrical power consumption. Pumps with automatic speed control may offer electrical energy savings. While solid fuel boilers do not usually have a minimum flow requirement, it should be verified that the use of these controls will not compromise the safe operation of the appliance and system.

Advice on pumps is available from the BPMA (British Pump Manufacturing Association) website at www.bpma.org.uk.

Table 1: Heat emitters

Type	Comment
Panel radiator	The most common type in modern housing. Available in a wide range of outputs and sizes.
'Compact' radiator	A radiator or convector fitted with top grille and side covers.
'Column' and 'designer' radiators	Available in a wide range of colours and shapes.
Low Surface Temperature (LST) radiator	Safe option where young children or the elderly may be at risk. Limited to a surface temperature of 43°C in order to prevent injury.
Towel rail	For towel warming and will give some heat to the bathroom.
Fan convector	Wall hung and 'kickspace' units available. These provide a more rapid heating response. They need an electrical supply and there may be some fan noise.

Section 7 - Controls

Installing effective controls can have a major impact on the energy consumption of heating and hot water systems. This section describes the types of controls now available and outlines which are most appropriate for different heating systems.

Effective controls will increase operating efficiencies, especially when older systems are being updated. They also provide the householder with the opportunity to minimise energy consumption by ensuring the right comfort temperatures are maintained and so reducing overheating. Reducing room temperatures will also save energy (see panel). Timed space and water heating periods will also help to avoid excessive use of energy. Heating fuel is expensive and reducing the amount of time operating at high output will make a proportionate difference to running costs.

What is a 'good' control system? It is one which ensures the boiler does not operate unless there is a demand and that only provides heat where and when it is needed in order to achieve the required temperatures. Most solid fuel appliances do not turn the heat off, therefore the control system must ensure that the burning rate is minimised when heat requirements are low. The selection of appropriate controls plays a key part in minimising the overall running costs of a heating or hot water system.

To maximise the efficiency of a heating system, control standards must meet Best Practice.

The cost benefit of controls should not be underestimated. Over 80 per cent of the energy a householder uses in the home is for space and hot water heating and the correct use of controls will have a major impact on consumption.

VAT on heating controls

Heating controls for domestic wet central heating systems are recognised by the Government as an energy efficiency measure. VAT is therefore charged at a lower rate - currently 5 per cent instead of the full rate of 17.5 per cent. This lower rate applies to both equipment and installation costs, but only when the work is carried out by an installer registered for VAT.

7.1 Individual controls

This section describes the range of controls commonly used in heating and hot water systems, what they do and why they are important.

The controls listed here are normally installed separately from the boiler. For clarity of specification, Appendix A contains a full list of controls, including those often fitted within appliances, and gives industry-agreed definitions.

In the following listing, Best Practice controls are noted.

Time Switch - A simple time control that will only switch one circuit. It should be chosen so that it is easy to understand and reset, especially when there is a change to the householder's domestic routine.

Programmer - This can switch two circuits separately (usually heating

and hot water). There are three basic types:

- a mini-programmer allows space heating and water to be on together, or hot water alone but not heating alone;
- a standard programmer uses the same time settings for space heating and hot water;
- a full programmer allows fully independent time setting for space and hot water heating.

Room thermostat - A simple room temperature control. Most room thermostats include an accelerator or anticipator, which has the effect of smoothing out the temperature cycle so that on and off periods are not too long. Wireless units are now available that provide increased flexibility in positioning and also eliminate visible wiring (see the following note on wireless controls).

Programmable room thermostat (Best Practice) -

This allows different temperatures to be set for different periods of the day or week and can provide a good match to householder living patterns (particularly if occupancy varies during this time). This device also has a 'night setback' feature where a minimum temperature can be maintained. Many of these models are battery-operated and can replace a conventional thermostat without the need for additional cabling. Some versions also allow time control of hot water provision.

Figure 7: A programmable room thermostat offers greater flexibility in setting temperatures and times than a standard room thermostat, producing greater savings

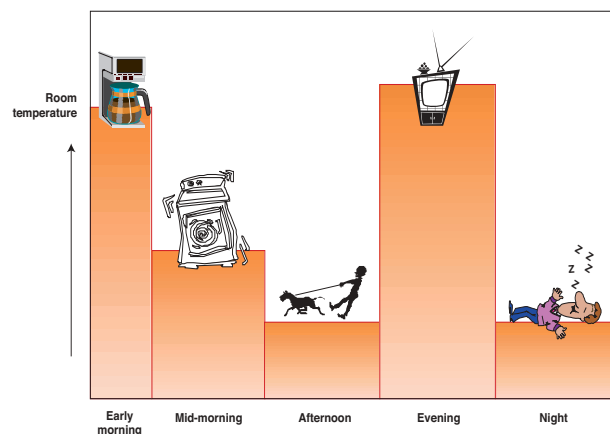

Cylinder thermostat (Best Practice) - A simple control of stored hot water temperature, usually strapped to the side of the hot water cylinder. It is commonly used with a motorised valve to provide close control of water temperature.

Section 7 - Controls

Pipe thermostat (Best Practice) - This may be fitted to part of the primary circulation system in order to prevent overheating. It should be connected electrically so that when activated the pump will dissipate excess heat in the system (it is typically set to 85°C). A pipe thermostat can also be used to turn the pump off if the boiler is operating at low temperatures. Manufacturers often recommend this as a way to prevent corrosion within the appliance (in which case it is normally set to 45-50°C).

Thermostatic radiator valve (Best Practice) - TRVs are used to limit the temperature in individual rooms. They also prevent overheating from solar and other incidental gains. In this way, they cut down on unnecessary consumption. They must not be fitted to a slumber radiator.

Motorised valve (Best Practice) - This is used to control water flow from the boiler to heating and hot water circuits. Two-port valves can also be used to provide zone control (e.g. allowing lower temperatures to be set for sleeping areas or different heating times). All two-port valves used in solid fuel systems must be 'normally open' (i.e. they only close when power is applied) to ensure safe operation in the event of power failure or malfunction. An explanation of different types is given in Appendix A.

Boiler interlock (Best Practice) - This is not a device, but rather a wiring arrangement to prevent the boiler firing when there is no demand for heat. It is not possible to switch off the heat output in most solid fuel systems. The concept of boiler interlock can still be applied in this case.

When there is no demand for heat, the appliance output is reduced to a minimum. This is the closest practical alternative to on/off control.

The boiler is 'interlocked' when its heat output is controlled by thermostats containing electrical switches. All thermostats in the heating system fitted with electrical switches should be wired in this way. This includes room thermostats, programmable room thermostats and cylinder thermostats.

For most solid fuel appliances, the thermostats will switch the pump off, which in turn will cause the boiler to operate at minimum heat output. How interlock is achieved will depend on the type of boiler and the controls fitted. Interlock is usually arranged so that the room or cylinder thermostat switches the pump directly, or through the motorised valve end-switch (i.e. when there is a demand for heat, the power from the thermostat de-energises the valve motor which 'springs back' to the open position). Once the valve is fully open, the end-switch closes and electric power is then passed to the pump. When power is restored to the valve (programmer off-period or the thermostat is satisfied) the end-switch opens and the pump will stop.

Table 2: Control functions

The following control functions are often built into boilers and control units.

Delayed start	Reduces energy use by delaying boiler start time when the weather is mild.
Optimum start	Adjusts the heating start time to give the required dwelling comfort temperature at a chosen time.
Night setback	Allows a low temperature to be maintained at night. Provides improved comfort and reduced dwelling warm-up time in cold weather. A programmable room thermostat can provide this facility.
Self-adaptive function	Reduces appliance 'on' time by learning from previous temperature characteristics.

Energy savings from good controls

- Installing a minimum standard of controls on a system which previously had none can reduce fuel consumption and CO₂ emissions by 18 per cent.
- Reducing higher than necessary room temperatures will cut energy use. Turning down the room thermostat by 1°C will reduce space heating consumption by 6-10 per cent.
- An easy to use programmer that is adjusted to match the householder's occupancy pattern helps reduce wasteful heating when no one is at home.

Wireless controls

Wireless controls should be designed with adequate immunity to blocking by other radio transmissions. If not, they may become unreliable or cease to work at all as nearby radio frequency bands become increasingly used. See Best Practice Note 7 (in Section 8) for details on how to specify wireless controls.

7.2 Selecting controls for Best Practice

The system controls and arrangement outlined here is recommended for Best Practice. All systems should be fully pumped where possible.

Solid fuel appliances cannot usually be switched on and off directly. Effective control can usually be achieved by operating the pump through a programmable room thermostat. Control of the hot water should be achieved with a cylinder thermostat linked to a 'normally-open' motorised valve. An overheat thermostat mounted on the flow pipe can operate the pump (and motorised valves if necessary) and so dissipate any excess heat. A low limit thermostat may also be fitted to prevent pump operation when the temperature is too low (this will help prevent boiler corrosion). TRVs should be fitted on all radiators except in rooms with a room thermostat or slumber radiator.

Figure 8 shows a typical controls arrangement for use with a solid fuel appliance. It should be noted that appliances may have specific requirements in regard to system design and the use of controls - manufacturers' instructions should always be followed.

In the event that it is not possible to meet Best Practice requirements, a semi-gravity system may be employed (Figure 9). The building regulations require the system to have timing and zone controls. This means that a programmer or room thermostat (or programmable room thermostat) is linked to the pump and that TRVs are installed (except in rooms with a room thermostat or slumber radiator). Where possible, thermostatic control of domestic hot water should also be installed.

In all cases, the appliance manufacturers' system installation requirements must be observed, particularly in regard to the suitability of the appliance for fully pumped operation. The system design must ensure that all heat generated when the boiler is slumbering is dissipated and that unsafe operation is prevented in the event of electricity or control failure.

Figure 8: Schematic of a fully-pumped system

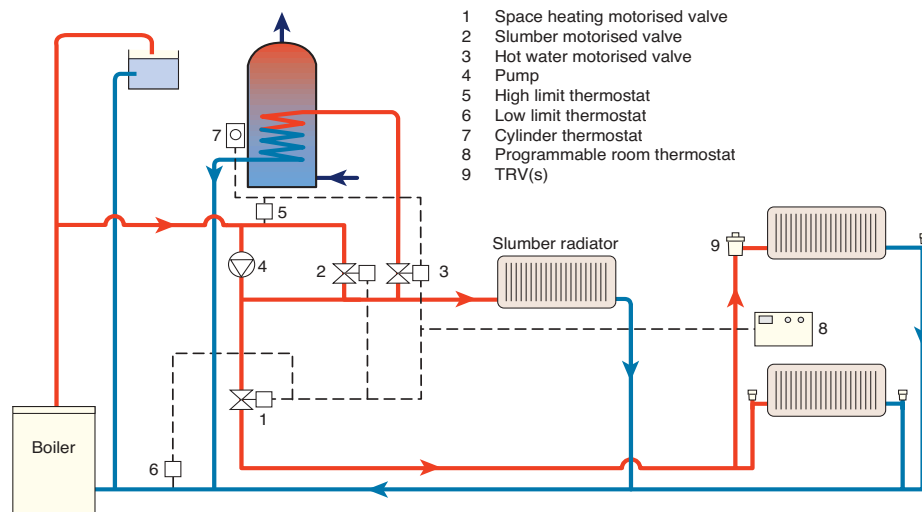
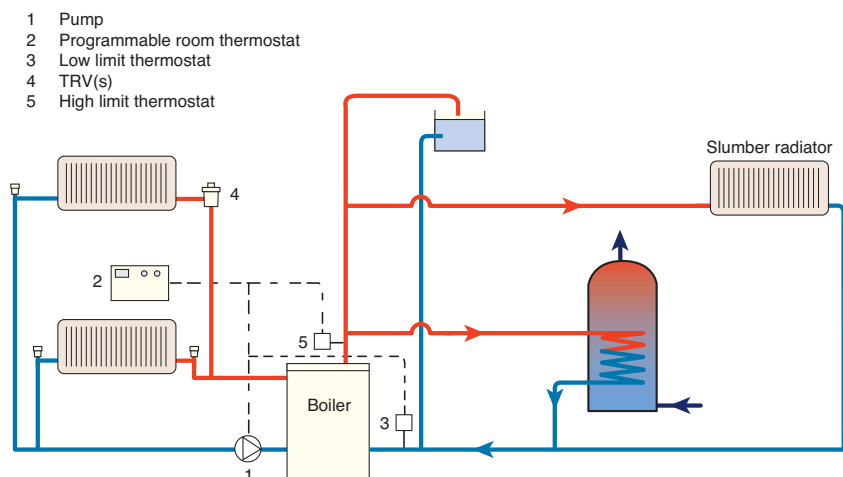

Figure 9: Schematic of a semi-gravity system



7.3 Further control improvements

Zone control- The Best Practice option already includes zone temperature control, achieved using TRVs. If zones are to be independently time controlled as well, it will usually be necessary to install additional room thermostats and a two-port motorised valve (spring-return, normally-open) to allow the programmer to shut off water circulation. The wiring in such situations must be arranged so that boiler interlock works in all zones.

Zone control is particularly beneficial in larger, poorly insulated buildings. Building regulations in England and Wales require that no zone is larger than 150m² in floor area and each zone should be capable of independent time and temperature control.

Figure 10: Zone controls

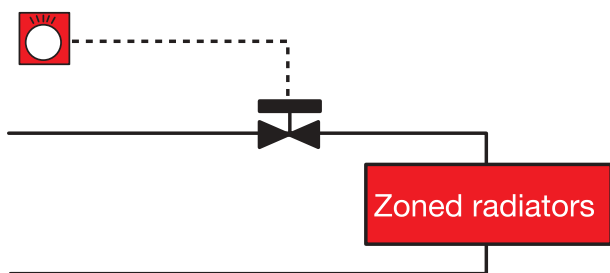

Delayed/optimum start - During mild weather, heat-up times are reduced. A delayed start function takes advantage of this. An optimum start control varies the start time to ensure the dwelling only reaches the desired temperature when the householder needs it (see Figure 11).

Figure 11: Delayed/optimum start function

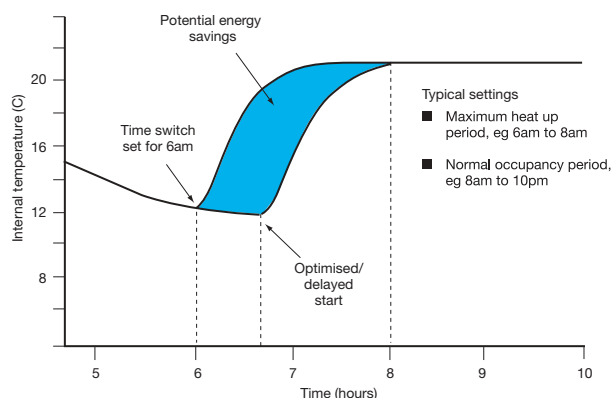

Section 8 - Best Practice

This guide covers most types of solid fuel appliance but concentrates on Best Practice. The most efficient appliances should be used to provide optimum performance with low running costs and reduced CO₂ emissions.

Best Practice requires:

- closed appliances that meet agreed minimum efficiency and emissions standards;
- appliances are to be sited in regularly used heating areas;
- the chimney should preferably be located near the centre of the dwelling;
- the appliances should not be used in summer when only domestic hot water is needed (although at the margins of the heating season it may

be appropriate to use it for this purpose).

This section outlines a ready-made specification for purchasing the components that critically affect the energy efficiency of a solid fuel wet central heating system. Following them will improve energy efficiency and reduce carbon emissions. However, appliance manufacturers' recommendations for system design and the installation of controls should always be adhered to.

Installers can use this specification to quote for systems of defined quality, comparable with those of their competitors.

Recommended Best Practice (2005)

Description	Domestic wet central heating system with solid fuel boiler and separate hot water store, for use with mineral fuel.
Appliance	<ul style="list-style-type: none">• Designed for use with mineral fuel or wood fuel in the form of logs or briquettes. HETAS approved appliance or equivalent (HETAS approved appliances are listed in 'the official guide to approved solid fuel products and services' ⁽²⁾). Types are: <ul style="list-style-type: none">- independent boiler;- stove/roomheater with boiler;- cooker with central heating boiler. All appliances must include a temperature thermostat which automatically adjusts combustion to maintain a set water temperature to within 2°C.
Hot water store	<ul style="list-style-type: none">• High Performance Hot Water Cylinder (see Note 4)
Controls	<ul style="list-style-type: none">• Boiler thermostat (see 'Appliance' above) (see Notes 5, 6, 7).• Programmable room thermostat.• Cylinder thermostat.• Boiler high temperature pipe thermostat.• Boiler low temperature pipe thermostat (if required).• Boiler interlock (see Note 8).• TRVs on all radiators, except in rooms with a room thermostat or slumber radiator.• Motorised valves (must be 'normally-open' type).
Feed and Expansion tank	<ul style="list-style-type: none">• The tank and all materials in contact with the water (e.g. the tank cover, ball valve, float) shall be capable of withstanding a temperature of 100°C.
Installation	See Notes 1, 2

Where it is not possible or practical to install the appliance in a fully pumped system, a semi-gravity system is acceptable providing controls as above are incorporated. It should be noted that most solid fuel appliances have specific requirements for system design and the use of controls and manufacturers instructions must always be followed.

1. **Other components:** The specifications list only the principal components of a heating system affecting energy efficiency. Other components will be required, such as radiators, circulator pumps and cisterns (feed and expansion tanks). All components must be selected and sized correctly.
2. **Design and installation:** Heating systems should be designed and installed in accordance with relevant safety regulations, manufacturers' instructions, building regulations^(2,3,4), and British Standards^(1,5,13).
3. **Boiler size and type:** The whole house boiler sizing method for houses and flats gives guidance on boiler size and is available on the website www.boilers.org.uk. Although SEDBUK (Seasonal Efficiency of a Domestic Boiler in the UK) efficiency information is not applicable to solid fuel boiler systems, the section 'Recommended boiler size' can be used. Note the comment in Section 5.2 - when sizing room heaters and stoves ensure the appropriate ratio of 'heat to room' and 'heat to water' is determined.
4. **Hot water cylinder:** Vented cylinders shall comply with BS 1566:2002 (where specified)⁽⁶⁾.
5. **Circuits and zones:** Systems must have separately controlled circuits to the hot water cylinder and radiators, and both circuits must have pumped circulation. Large properties must be divided into zones not exceeding 150m² floor area, so that the operation of the heating in each zone can be timed and temperature controlled independently.
6. **Definitions of heating controls** are given in Appendix A.

7. **Wireless controls** should be designed with a satisfactory level of immunity to blocking by other radio transmissions. Otherwise they may become unreliable, or cease to work, as nearby radio frequency bands become increasingly heavily used for mobile phone and other communication services.

Compliance with the essential requirements of the European Radio and Telecommunications Terminal Equipment (RTTE) Directive 1999/5/EC is insufficient, as the directive is designed only to ensure that wireless products do not cause harmful interference to other transmissions. It does not give any assurance that the product has a satisfactory level of immunity to interference from other radio transmissions.

Consequently it is not sufficient for the manufacturer to confirm compliance with the RTTE Directive. The manufacturer should also confirm that the switching range (and preferably alignment range) does not include any frequencies below 430MHz, and that in regard to ETSI EN 300 220-1 v1.3.1 (see Ref[15]) the receiver classification (clause 4.1.1) is either Class 1 or Class 2, and the device is marked in accordance with clause 4.3.4.

8. **Boiler interlock** is not a physical device but an arrangement of the system controls (room thermostats, programmable room thermostats, cylinder thermostats, programmers and time switches) so as to ensure that the appliance does not operate when there is no demand for heat. Most solid fuel appliances are designed for continuous high/low operation (not on/off) and therefore boiler interlock should allow the appliance to operate at minimum rate. In a system which has a boiler with a boiler thermostat, it can be achieved by correct wiring interconnection of the room thermostat, cylinder thermostat, and motorised valve(s) and pump. It may also be achieved by more advanced controls, such as a boiler energy manager.

This guide provides information designed to lead to improved energy efficiency. Selection of the most suitable and energy-efficient appliances is vital to that process. Appliance selection should consider:

- the seasonal (i.e. annual in-use) efficiencies of the different options;
- the typical running costs for heating and hot water in the dwellings concerned;
- the typical CO₂ emissions associated with space and water heating.

The Standard Assessment Procedure (SAP) is used to assess the overall energy efficiency of new and refurbished dwellings⁽¹⁵⁾ and the result is affected by the type of heating system chosen. The SAP document provides average seasonal efficiency values based on the gross calorific value of the fuel used (see Table 3).

Case emissions from a solid fuel appliance are generally high and so there is a noticeable difference between the efficiencies (i.e. of useful delivered energy) in heated and unheated areas. The chimney also has a heat storage effect. For Best Practice it is essential that appliances are located in a room that the householder regularly wants to heat.

To indicate the comparative efficiencies of different appliance types, Table 4 shows the laboratory test efficiencies based on gross calorific value of mineral fuel. However, these should not be compared with seasonal efficiencies because they do not take account of the variation in operating conditions through the year, nor the potential heat gains from the chimney.

9.1 The Standard Assessment Procedure (SAP)

Home energy ratings are designed to give an indication of the energy efficiency of a dwelling and so allow householders to compare different homes. The SAP is the Government's chosen rating system and indicates the running costs of space and water heating. The building regulations require all new dwellings to be assessed in this way.

SAP ratings are expressed on a scale of 1-120, with higher figures representing greater efficiency and lower running costs. The actual figure depends on certain characteristics of the building and its heating systems, in particular:

- building design;
- insulation levels;
- solar heat gains;
- ventilation;
- heating and hot water efficiency and controls.

Table 3 shows the seasonal efficiencies used in SAP 2001 for solid fuel central heating. The values have been used to calculate the energy consumption and CO₂ emissions shown in Tables 5 and 6.

Table 3: Central heating seasonal efficiencies (Source: SAP)

Appliance type	As referred to in SAP 2001	Seasonal efficiency (%)
Independent boiler	Manual feed (in heated space)	60
Independent boiler	Manual feed (in unheated space)	55
Independent boiler	Autofeed (in heated space)	65
Independent boiler	Autofeed (in unheated space)	60
Open fire with BBU*	Open fire with back boiler to rads	55
Stove/roomheater with BBU*	Closed fire with back boiler to rads	65

* BBU refers to Back Boiler Unit

Table 4: Typical appliance efficiencies (based on gross calorific value - CV - of burning anthracite)

Type	Description (%)	Test Efficiency (gross CV)	
		Typical	HETAS minimum
Room heating	Open fire (to BS 4834)	43	37
	Stove	73	65
Space and water heating	Open fire with (high output) BBU	73	65
	Cooker with (high output) BBU	72	60
	Independent boiler	78	70

9.2 Energy consumption and running costs

Table 5 gives typical annual fuel costs for some of the more common types of dwelling found in the UK - both existing properties and new buildings. They are typical of the existing housing stock⁽¹⁷⁾. The new housing has the same floor areas, but is built with insulation levels that would satisfy the latest building regulations for gas heating. The flat is on the top floor. Hot water costs are related to a typical number of occupants.

Figures shown assume average UK weather conditions (the Midlands). Consumption would be around 3-6 percent lower in the south and 3-6 percent higher in the north.

Typical energy consumption has been calculated using the BRE Domestic Energy Model, BREDEM-12⁽¹⁶⁾, which estimates annual domestic energy usage associated with: house design, insulation levels, local climate, and type of heating system, including efficiency and heating usage. The model is widely used for calculating running domestic fuel running costs.

Fuel costs have been taken from the 2001 edition of the SAP (Table 12):

- house coal - 1.66 p/kWh
- anthracite - 1.86 p/kWh
- smokeless fuel - 2.69 p/kWh

These costs do not include maintenance or circulating pump running costs.

Table 5: Annual fuel costs for heating and hot water in different property types

Boiler type (closed appliance installed in heated space)	Seasonal efficiency	EXISTING HOUSING					NEW HOUSING				
		Flat	Bungalow	Terraced	Semi-Detached	Detached	Flat	Bungalow	Terraced	Semi-Detached	Detached
Batch feed (house coal)	60%	£257	£336	£350	£396	£562	£84	£105	£105	£131	£156
Batch feed (anthracite)	60%	£287	£375	£391	£442	£627	£93	£117	£117	£146	£174
Batch feed (smokeless fuel)	60%	£414	£542	£565	£640	£907	£135	£170	£170	£211	£252
Gravity feed (anthracite)	65%	£265	£346	£361	£408	£579	£86	£108	£108	£135	£161

9.3 Carbon dioxide emissions

Table 6 shows typical values, in tonnes of CO₂ per year, of emissions for the same types of dwellings as those in Table 5. Carbon intensity values are taken from SAP 2001 Table 15.

Table 6: CO₂ emission (tonne/yr) for solid fuel heating and hot water in different property types

Boiler type (closed appliance installed in heated space)	Seasonal efficiency	EXISTING HOUSING					NEW HOUSING				
		Flat	Bungalow	Terraced	Semi-Detached	Detached	Flat	Bungalow	Terraced	Semi-Detached	Detached
Batch feed (house coal)	60%	4.50	5.89	6.13	6.95	9.85	2.09	2.63	2.63	3.28	3.90
Batch feed (anthracite)	60%	4.88	6.40	6.66	7.55	10.70	2.27	2.86	2.86	3.56	4.24
Batch feed (smokeless fuel)	60%	6.05	7.92	8.25	9.35	13.25	2.81	2.54	3.54	4.41	5.25
Gravity feed (anthracite)	65%	4.51	5.90	6.15	6.97	9.87	2.09	2.64	2.64	3.29	3.92

Section 10 - System selection - practical issues

Choosing the right central heating system involves determining:

- the heating and hot water requirements of the household;
- the type of boiler to use and where it should be positioned;
- the type of heating and hot water system;
- the controls to be installed.

There are also a number of practical decisions to be taken. In this section they are considered in a simple and logical manner. The key questions to be addressed are as follows.

- 1 What appliance should be chosen?
- 2 What size appliance is required?
- 3 Where will the system be positioned?
- 4 What chimney arrangements are required?
- 5 What are the ventilation requirements?
- 6 What are the central heating system requirements?
- 7 What type and size of heat emitters are required?
- 8 What central heating controls are needed?

10.1 What appliance should be chosen? (5,18)

Room heating only	Use HETAS approved closed appliance preferably with thermostatic control.
Wet central heating	Use HETAS approved closed appliance with thermostatic control.
Open fire with BBU	The simpler open fire is the least efficient in operation and not recommended. High efficiency open fires are available. Converting an open fire using a 'firefront' will increase efficiency.
Stove with BBU	Provides reasonably high efficiency providing an appliance with thermostatic control is selected.
Independent boiler	Have the highest efficiency and capable of the greatest turn-down.
Cooker with BBU	This has a relatively high standby loss and may result in uncomfortable ambient temperatures in summer.

10.2 What size appliance is required? (1,12,19,26)

Size for maximum load	A boiler should be sized so that it can satisfy the maximum load imposed by the heat emitters, hot water system and distribution pipework.
New heating systems	A full design heat loss method should be employed to ensure the most appropriate boiler is selected.
Boiler replacements	Size for size replacement is not recommended. The heating and hot water requirements should be ascertained before the new boiler is ordered, since insulation levels may have increased, or the original sizing may have been incorrect. Oversizing will lead to less efficient operation as well as increased capital cost. An interactive procedure for boiler sizing up to 25kW is provided at www.boilers.org.uk .
Roomheaters/stoves	Where back boiler units are included, care must be given to ensure the correct 'heat-to-room' and 'heat-to-water' ratio is achieved.

10.3 Where will the system be positioned? (1,2,3,4,5,18)

Space	Is it adequate - including space for chimney and hearth?
Access	Is this adequate for installation, maintenance and servicing?
Chimney	Will the appliance be in a suitable position to connect to an existing or new chimney? The chimney should preferably be located near the centre of the house.
Hearth	This must comply with building regulations.
In a heated area?	Preferable - saves energy.
In a unheated area?	This will result in undesirable heat loss.

10.4 What chimney arrangements are required? (1,2,3,4,5,18,27)

Existing chimney	Is it of suitable design and construction? Is it in serviceable condition?
New masonry or prefabricated chimney	<p>Consider:</p> <ul style="list-style-type: none"> • Height • Size • Insulation • Flue terminal design • Availability of a straight flue route • Access for cleaning • Air tightness <p>Refer to building regulations:</p> <ul style="list-style-type: none"> • Part J - England & Wales⁽²⁷⁾; • Section 3: Environment, of the Domestic Technical Handbook - Scotland⁽²⁸⁾; • Part L - Northern Ireland⁽²⁹⁾.

10.5 What are the ventilation requirements? (2,3,4,5)

Vents	All appliances require a correctly-sized purpose-made, non-closable vent to ensure sufficient air for combustion. It should be sited so as to minimise cold draughts.
Extract fans	These should not be sited in the same room as a solid fuel, open-flue appliance. If an extractor fan is fitted in the dwelling, additional ventilation may be required in the same room to avoid negative pressure affecting the operation of the chimney.

10.6 What are the central heating system requirements? (1,6,12,18)

Primary system design	It must be an open-type system with a dedicated feed and expansion cistern. Sealed systems must not be used unless this is specifically recommended by the appliance manufacturer.
Cold feed and vent	The appliance must have a dedicated cold feed and an open vent.
Hot water cylinder	This must conform to BS1566-1:2002 - where required, double feed, indirectly heated, suitable for gravity operation (cylinders labelled G are being introduced). Some manufacturers specify a larger than normal cylinder to absorb heat when the boiler is operating at its minimum firing rate.
Slumber circuit	To be sized as recommended by the appliance manufacturer. It must connect to a boiler using a gravity circuit that does not have user-operated valves or TRVs.
Link-up	This provides the benefits of having an attractive focal point fire with possible lower running costs when using gas or oil. However, there are significantly higher capital costs. Safety and design aspects need to be checked, particularly in regard to system hydraulics. Proprietary systems are available.
Pipe insulation	Heating and hot water pipework must be insulated in accordance with building regulations, from both an energy and a frost protection standpoint.

10.7 What type and size of heat emitters are required? ^(1,12,18,19)

Heat emitter type	Panel radiators offer the lowest cost option. Use Low Surface Temperature (LST) radiators where young children or elderly are likely to be present and may be at risk.
Size	Use full design heat loss calculations. Avoid undersizing as this will result in unsatisfactory heating performance. Visit www.centralheating.co.uk for more information.
Slumber radiator	This must be sized to dissipate excess heat and must not include user-operable valves to flow and return connections.

10.8 What central heating controls are needed? ^(1,12)

Best Practice	Use fully-pumped systems where possible and practical.
TRVs	These should be installed on all radiators. Except in rooms with a room thermostat or that include gravity (slumber) radiators.
Pumps	Advice on pump selection is available at www.bpma.org.uk . See Section 6.6 in relation to pumps with automatic speed control.
Very large dwellings	These should be divided into separate zones not exceeding 150m ² in floor area. Each zone should be capable of independent time and temperature control.
Other controls	Additional controls can be beneficial - see Section 7.3.

11.1 'Competent person' requirements

In England and Wales, the installation or replacement (or alteration to the position) of a solid fuel combustion appliance is subject to building regulations. A 'competent person' undertaking an installation is required to complete a HETAS Installation and Commissioning Certificate which provides details of the installation. A signed copy of this certificate is sent to HETAS, a copy is left with the owner of the dwelling and a copy is retained for the installing company's records. From the 1 April 2005 HETAS will additionally send an electronic version of this certificate to the Local Authority Building Control Department. An individual registered under the Solid Fuel Registration Scheme run by HETAS is deemed competent to install solid fuel equipment and can undertake this work. Alternatively installers or their customers can use the Local Authority Building Control route for notification for which a charge is made.

Other parts of the United Kingdom are considering the adoption of similar arrangements.

11.2 Chimneys

For installation issues relating to chimneys, refer to information in the building regulations and also to the advice available from manufacturers, BFCMA, NACE, the Solid Fuel Association and the HETAS 'Guide'.

11.3 Installing controls

The main issues to be considered when installing the most commonly used domestic central heating controls are described in this section.

Programmable Room Thermostat Best Practice specification



A programmable room thermostat should be located in a regularly heated area. While free movement of air is important, it should be mounted away from draughts, internal heat sources and direct sunlight. It should not be fitted in a room where supplementary room heating (such as electric heaters or open fires) can affect it. So do not site one in a kitchen or combined kitchen/living room. Only install one in a main living room if it is certain that no supplementary heating is used there. Appropriate positions would be in the hall or a living room without supplementary heating.

The unit should be readily accessible to the householder, not hidden away in a cupboard or behind furniture. It should be located at a height of about 1.5m above floor level (unless the occupants include wheelchair users, where a suitable height in excess of 1m should be agreed with the homeowner).

Time switch/programmer Basic systems only



Time switches can only switch one circuit, while programmers can control two (e.g. heating and hot water), so ensure that the unit is appropriate.

These controls should be installed where they can be easily reached, read and altered. Do not fit them in places inconvenient for the householder (e.g. in an airing cupboard).

Room thermostat Basic systems only



Installation considerations are the same as for the programmable room thermostat.

Cylinder thermostat Best Practice specification



This control is usually strapped onto the cylinder about one third of the way up from the base - the strap needs to be tight to ensure good thermal contact. It should be adjusted to about 60°C: if set too high, it may result in scalding, but if too low it can increase the risk of legionella bacteria which could result in serious health problems⁽¹²⁰⁾.

Motorised valve Best Practice specification



Solid fuel systems must include 'normally-open' motorised valves so that gravity circulation can be maintained in the event of a control or power failure. Motorised valves must not be positioned in the line of the open safety vent pipe or the feed-and-expansion pipe.

Thermostatic Radiator Valve (TRV) Best Practice specification

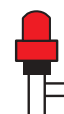

TRVs must be used in systems meeting either specification. They should be installed in all rooms - except those in which a controlling room thermostat provides a boiler interlock. Many TRVs can be fitted on the flow or return to the radiator and many are bi-directional (if not, the direction of the water flow must be taken into account when installing them).

11.4 Water treatment

New and existing systems must both be cleaned and flushed before use. A suitable corrosion inhibitor should also be used to prevent a build-up of scale and corrosion. The appliance manufacturer's recommendations must be followed in this area as damage may result from unsuitable treatment. For both new and replacement systems, cleaning is essential and, if recommended in the appliance manufacturer's instructions, a suitable chemical cleaning agent can be used. When a boiler is replaced it is essential to drain and flush all old water from the system in case it contains a corrosion inhibitor unsuitable for the replacement. Further advice on the need for treatment, and on causes of problems and methods of treatment can be found in publications listed at the end of this document^(1,20).

11.5 Fuel storage

There should be a weatherproof, robust fuel store with easy access for delivery and removal of fuel. The store should be capable of containing at least six weeks supply (for mineral fuel this should be at least 0.5 tonne). The opening through which the fuel is tipped should be not less than 0.6m² and not more than 1.4m high.

12.1 Commissioning

When a new or replacement system (including the appliance) is installed it is important to verify that it is functioning safely and efficiently.

- The installation must be checked for compliance with the building regulations and an installation and commissioning certificate issued - completed by the 'competent person' in England and Wales. A suitable certificate is available to members of the Competent Persons Registration Scheme.
- A notice plate with the performance characteristics of the hearth, fireplace, flue and chimney is to be fixed in an appropriate place in the dwelling. This plate is available from a number of sources.
- Confirmation should be sought from the local authority on whether the installation is covered by a 'smoke control order'. If so, the fuel used must be an authorised 'smokeless' fuel or the appliance must be an appliance exempted by DEFRA under the Clean Air legislation.
- The boiler and system should be cleaned using a recognised flushing procedure.
- The key appliance and systems components should be checked for proper operation and controls set to optimum settings.
- The customer should be instructed on how to operate the controls, the importance of servicing the appliance and the system regularly, and of the need for chimney sweeping at the intervals recommended for the type of fuel burned.

12.2 Advice to the householders

Installers must instruct the householder how to set and use the controls properly and effectively. In particular, the operation of programmers can be difficult to understand and homeowners will gain little or no benefit from an incorrectly set device. Indeed, they will probably end up wasting energy.

As a bare minimum, the manufacturer's instructions should be left with the householder. However, it will usually be necessary to demonstrate:

- how to set the programmer clock and adjust for GMT and BST;
- the use of the time control override function;
- how to set room and cylinder thermostats;
- how to set TRVs.

The installer will also need to explain:

- the function of room thermostats and TRVs (for example, that they should be left alone once set, rather than used as on/off switches);
- the correct procedure for emptying the ash pan and cleaning the appliance;
- that the cylinder thermostat needs to be left at approximately 60°C, since setting it higher may result in scalding while setting it lower can allow the growth of legionella bacteria;
- that the radiator lockshield valves should not be adjusted once set by the installer;
- why it is best to turn off solid fuel appliances when only water heating is required;

- why it is best to turn the room thermostat down to frost protection levels (typically around 12°C) when the dwelling is unoccupied (unless a separate frost protection system has been fitted);
- what may happen to the system if there is a power cut.

12.3 Servicing

Users should be made aware of the importance of regular servicing - both of the boiler and the system as a whole. This will help maintain its safety and efficiency. There should be a regular service contract with a service engineer recognised as competent by HETAS, who will clean and maintain the boiler as well as checking the operation of the system and controls. The chimney should be inspected and cleaned by an Approved Chimney Sweep. Further information can be obtained from the National Association of Chimney Sweeps (NACS)⁽²⁴⁾, the Guild of Master Sweeps (GMS)⁽²⁵⁾ and HETAS⁽²¹⁾.

General servicing should take place at least once a year. Parts of some appliances (such as the throat plate) may need to be cleaned on a monthly or even weekly basis. Owners should refer to the manufacturer's instructions.

Appendix A - Definitions of heating controls

Boiler interlock

This is not a physical device but an arrangement of the system controls so as to ensure that the boiler does not fire when there is no demand for heat. In a system which has a boiler with a boiler thermostat it can be achieved by correct wiring interconnections between the room thermostat, cylinder thermostat, and motorised valve(s). It may also be achieved by a suitable boiler energy manager (see Section 7.1 for further details of how interlock can be applied to solid fuel appliances).

Boiler thermostat

A thermostat within the boiler casing to limit the temperature of water passing through the boiler by regulating the combustion air control. The target temperature may either be fixed or set by the user.

Cylinder thermostat

A sensing device to measure the temperature of the hot water cylinder and switch on and off the water heating. A single target temperature may be set by the user.

Delayed start

A device, or feature within a device, to delay the chosen starting time for space heating according to the temperature measured inside or outside the building.

Frost thermostat

A device to detect low air temperature and switch on heating to avoid frost damage, arranged to override other controls.

Motorised valve

A valve to control water flow, operated electrically. A two-port motorised valve controls water flow to a single destination. A three-port motorised valve controls water flow to two destinations (usually for space heating and hot water), and may be either a diverter valve (only one outlet open at a time) or a mid-position valve (either one, or both, outlets open at a time).

The valve movement may also open or close switches, which are used to control the boiler and pump.

Night setback

A feature of a room thermostat that allows a lower temperature to be maintained outside the period during which the normal room temperature is required.

Optimum start

A device, or feature within a device, to adjust the starting time for space heating according to the temperature measured inside or outside the building, aiming to heat the building to the required temperature by a chosen time.

Optimum stop

A device, or feature within a device, to adjust the stop time for space heating according to the temperature measured inside (and possibly outside) the building, aiming to prevent the required temperature of the building being maintained beyond a chosen time.

Pipe thermostat

A switch governed by a sensor measuring pipe temperature, normally used in conjunction with other controls such as a frost thermostat.

Programmable room thermostat

A combined time switch and room thermostat that allows the user to set different periods with different target temperatures for space heating, usually in a daily or weekly cycle.

Programmer

Two switches operated by a clock to control both space heating and hot water. The user chooses one or more 'on' periods, usually in a daily or weekly cycle. A mini-programmer allows space heating and hot water to be on together, or hot water alone, but not heating alone. A standard programmer uses the same time settings for space heating and hot water. A full programmer allows the time settings for space heating and hot water to be fully independent.

Room thermostat

A sensing device to measure the air temperature within the building and switch on and off the space heating. A single target temperature may be set by the user.

Self-adaptive (or self-learning) control

A characteristic of a device (of various types) that learns from experience by monitoring, and modifies its subsequent behaviour accordingly.

Temperature and time zone control (or full zone control)

A control scheme in which it is possible to select different temperatures at different times in two (or more) different zones.

Time switch

An electrical switch operated by a clock to control either space heating or hot water, or both together but not independently. The user chooses one or more 'on' periods, usually in a daily or weekly cycle.

Thermostatic radiator valve

A radiator valve with an air temperature sensor, used to control the heat output from the radiator by adjusting water flow.

Zone control

A control scheme in which it is possible to select different times and/or temperatures in two (or more) different zones.

- 1 BS 5449:1990 incorporating Amendment No. 1 issued March 2002, Specification for forced circulation hot water central heating systems for domestic premises
- 2 The Building Regulations 2000. Approved Document L1, Conservation of fuel and power in dwellings, 2002 Edition. See website www.odpm.gov.uk.
- 3 Section 6: Energy, of the Domestic Technical Handbook on possible ways of complying with the Building (Scotland) Regulations 2004. See website www.sbsa.gov.uk
- 4 The Building Regulations (Northern Ireland) 1994. Technical booklet F, Conservation of fuel and power (December 1998). See website www2.dfpni.gov.uk/buildingregulations/
- 5 BS 8303-1,-2 and -3:1994 Installation of domestic heating and cooking appliances burning solid mineral fuels.
- 6 BS 1566:2002, Copper indirect cylinders for domestic purposes
- 7 BS 3198:1981, Specification for copper hot water storage combination units for domestic purposes.
- 8 The Building Regulations 2000. Approved document J - Combustion appliances and fuel storage systems (2002 edition)
- 9 The Weights and Measures Act 1985 (Metrication)(Amendment) Order 1994
- 10 Trades Description Act, DTI, 1968.
- 11 Clean Air Act, 1993.
- 12 Domestic Heating Design Guide May 2003, CIBSE Domestic Building Services Panel.
- 13 BS 7671:2001, Requirements for electrical installations, IEE Wiring Regulations, Sixteenth edition
- 14 European Standard (Telecommunications series) ETSI EN 300 220-1 v1.3.1 (2000-09) : Electromagnetic compatibility and Radio spectrum Matters (ERM); Short Range Devices (SRD); Radio equipment to be used in the 25 MHz to 1000 MHz frequency range with power levels ranging up to 500mW; Part 1: Technical characteristics and test methods
- 15 The Government's Standard Assessment Procedure for Energy Rating of Dwellings, 2001 Edition
- 16 BREDEM-12, Building Research Establishment Report BR315. BRE, Garston, 1996
- 17 BRE Report BR354 : Domestic Energy Fact File 1998, L D Shorrocks and G A Walters
- 18 Solid Fuel Association website www.solidfuel.co.uk
- 19 Heating and Hot Water Information Council web site www.centralheating.co.uk
- 20 BS 7593:1992, Code of Practice for Treatment of water in domestic hot water central heating systems
- 21 HETAS web site www.hetas.co.uk
- 22 British Flue and Chimney Manufacturers Association website on www.feta.co.uk/bfcma
- 23 The National Association of Chimney Engineers website on www.nace.org.uk
- 24 The National Association of Chimney Sweeps website on www.chimneyworks.co.uk
- 25 The Guild of Master Sweeps website on www.guild-of-master-sweeps.co.uk
- 26 Boiler Efficiency Database: see website www.boilers.org.uk
- 27 BS 6461, Installation of chimneys and flues for domestic appliances burning solid fuel (including wood and peat).
- 28 Section 3: Environment, of the Domestic Technical Handbook on possible ways of complying with the Building (Scotland) Regulations 2004. See website www.sbsa.gov.uk
- 29 The Building Regulations (Northern Ireland) 2000. Technical booklet L, Combustion Appliances and Fuel Storage Systems). See website www.dfpni.gov.uk/buildingregulations



CE47

Energy Efficiency Best Practice in Housing

Domestic heating: solid fuel systems

Guidance for installers and specifiers

This publication (including any drawings forming part of it) is intended for general guidance only and not as a substitute for the application of professional expertise. Anyone using this publication (including any drawings forming part of it) must make their own assessment of the suitability of its content (whether for their own purposes or those of any client or customer), and the Energy Saving Trust (EST) cannot accept responsibility for any loss, damage or other liability resulting from such use.

Energy Efficiency Best Practice in Housing

Helpline: 0845 120 7799

Fax: 0845 120 7789

Email: bestpractice@est.org.uk

Web: www.est.org.uk/bestpractice

Energy Efficiency Best Practice in Housing is managed by the Energy Saving Trust on behalf of the Government.
CE47 © Energy Saving Trust. March 2005. E&OE.

All technical information was produced by the Building Research Establishment (BRE) on behalf of the EST.



Printed on Revive Silk which contains 75% de-inked post consumer waste and a maximum of 25% mill broke.